

RESTRICTED



Development Construction Manual

April 2026



CONTENTS

SECTION 1 - Introduction and Background	10
1.1 Scope of the Manual	10
1.2 Status of the Manual	10
1.3 Glossary of Terms.....	11
1.4 Approval Process.....	15
1.5 Other Relevant Documents.....	15
1.6 Advance Payment Code (APC).....	17
1.7 Maintainability Audits	19
1.8 Types of Legal Agreements	20
Section 38.....	20
Section 106.....	22
Section 228.....	22
Section 278.....	23
Section 72.....	24
Minor Works Authorisation	24
Section 171 Road Opening Notice for Trial Hole Investigation Works	25
1.9 Other Agreements	25
1.10 Payment of Costs.....	27
1.11 Compensation	27
Protection of Residents from Excess Noise	27
1.12 Technical Approval Process.....	28
Time Scale	28
Identification	28
Design Standards.....	29
Layout.....	29
Survey Data	29
Geometric Design	30
Visibility	30
Drainage	31
Earthworks	32
Pavement Design.....	32
Construction Details.....	32
Traffic Signs and Road Markings	33
Structures	33
Safety Fences and Other Street Furniture.....	33
Street Lighting and Illuminated Signs.....	34
Bus Stops – (See also Appendix F – Bus Infrastructure)	34
Traffic Signals	34
Site Limits and Highway Boundary.....	34
Statutory Undertakers.....	34
Landscaping.....	35
Road Safety Audit.....	35
1.13 Formal Technical Approval.....	35
1.14 Pre-Construction Requirements for a Section 38 Agreement.....	36
1.15 Pre-Construction Requirements for a 106/278 or Minor Works Authorisation Agreement	37

1.16 Other Pre-Construction Requirements	38
New Roads and Street Works Act 1991 (NRSWA)	38
Liaison with the Public and Other Bodies.....	39
Emergency Contacts.....	40
1.17 Construction.....	40
Protection of the Public.....	40
Construction (Design and Management) Regulations 2015 (CDM 2015)	40
Supervision Responsibilities	40
Inspection	41
Inspection Notification.....	41
Hours of Working	42
Provisions for Resident Engineers	42
Design Changes	42
Traffic Signals	42
Utilities	42
1.18 Post Construction	43
Part 1 Certificate (for 38 works only)	43
Completion Certificate (Part 2 certificate for 38 works)	43
Maintenance/Final Certificate (for 278 and 38 works)	44
SECTION 2 – Design Standards.....	46
2.1 Introduction	46
2.2 Adoptable Roads (Excludes Industrial Estate Roads – See Clause 2.9).....	46
2.3 Footways and Cycle Tracks	46
Cycle Track Design Requirements Visibility.....	46
Radius of Curvature.....	46
Gradients.....	47
Crossfall	47
Traffic Calming	47
Surface Finish	47
2.4 Structures	47
Structural Inspection Process.....	48
2.5 Surface Water Drainage.....	50
General.....	51
Highway Drains	51
Private Drains	53
Storage	53
Gullies	54
Soakaways and other Infiltration Features	55
Petrol Interceptors	55
2.6 Street Lighting	56
2.7 Passively Safe Signposts, Lighting Columns and Traffic Signal Poles.....	56
2.8 Car and Cycle Parking	57
2.9 Industrial Estate Roads	58
General.....	58
Visibility.....	59
Turning Spaces	59
Gradients.....	59
Construction Design	60
Access.....	60
Parking.....	60
2.10 Public Transport (see also Appendix F – Passenger Transport Infrastructure Standards	

Guide – Abridged Version)..... 60

2.11 Traffic Regulation Orders (TRO)..... 61

2.12 Public Rights Of Way (PROW) 62

SECTION 3 – General Requirements 64

3.1 Existing Street Furniture and Fittings 64

3.2 Protection of the Public..... 64

3.3 Protection of Existing Structures, Walls, Fences etc 64

3.4 Protection of Water Courses 64

3.5 Protection of Existing Trees and Landscaping 65

3.6 Control of Noise 65

3.7 Working Adjacent to Existing Highways 65

3.8 Openings in Publicly Maintainable Highways 66

3.9 New Roads and Street Works Act 1991 (NRSWA)..... 66

3.10 Construction (Design and Management) Regulations 2015 (CDM)..... 66

3.11 Road Safety Audits 67

3.12 Preliminary Site Meeting and Inspections 67

3.13 Commencement and Programme of Works 68

3.14 Project Engineering Drawings..... 69

3.15 Setting Out 69

3.16 Cold Weather Working..... 69

3.17 Construction Levels..... 70

3.18 Routing of Construction Vehicles 70

3.19 Keeping Highways Clean 71

3.20 Parking for Site Staff..... 71

3.21 British Standards Specification..... 71

3.22 Testing – General 71

3.23 Ground Investigation and Design CBR 72

3.24 Tests for Structures 73

3.25 Bulk Density and Air Void Determination of Bituminous Materials 73

3.26 Determination of Layer Thickness and Bond 73

3.27 Minimum Length of Road Construction 74

3.28 Carbon Reduction 74

SECTION 4 - Materials and Workmanship 75

4.1 Introduction 75

4.2 Site Clearing and Earthworks 75

 4.2.1 Order of Earthworks 76

 4.2.2 Site Clearance..... 76

 4.2.3 Trees and Hedgerows..... 76

 4.2.4 Removal of Topsoil 76

4.2.5 Bulk Excavation and Filling	77
4.2.6 Treatment of Unsound Ground	77
4.2.7 Excavations for Carriageways	78
4.2.8 Treatment of Side Slopes	78
4.2.9 Filling Materials - General	79
4.2.10 Materials for Embankments	79
4.2.11 Forming of Embankments	79
4.2.12 Maximum Moisture Content	80
4.2.13 Embankments Over Culverts	80
4.2.14 Temporary Drainage of Earthworks	81
4.2.15 Preparation of Formation	81
4.2.16 Soft Spots	81
4.3 Foul, Surface Water and Subsoil Drainage	81
4.3.1 Excavation of Trenches	82
4.3.2 Dealing with Water	82
4.3.3 Concrete Pipes and Specials	82
4.3.4 Concrete Perforated Pipes	82
4.3.5 Concrete Porous Pipes	82
4.3.6 Vitrified Clay Pipes Fittings and Ducts	83
4.3.7 UPVC Pipes	83
4.3.8 Iron Pipes	83
4.3.9 Laying and Jointing Pipes with Flexible Joints	83
4.3.10 Mortar	83
4.3.11 Type of Brickwork Bond and Mortar Laying Joints	84
4.3.12 Damage to Joints	84
4.3.13 Concrete Bed and Haunch	84
4.3.14 Concrete Protection	84
4.3.15 Testing of Pipelines	85
4.3.16 Filling Materials – Backfilling of Trenches	85
4.3.17 Backfilling of Trenches	85
4.3.18 Completion of Drainage	85
4.3.19 Subsoil and French Drains	86
4.3.20 Connections to Existing Sewers and Drains	86
4.3.21 Gully Connections	86
4.3.22 Temporary Stoppers	87
4.3.23 Gully Pots for Carriageways	87
4.3.24 Gully Gratings and Frames	87
4.3.25 Footpath and Cycle Track Gullies	88
4.3.26 Setting of Gully Pots/ Gully Gratings/ Frames	88
4.3.27 Catchpits, Manholes and Chambers – General	88
4.3.28 Precast Concrete Manholes Chambers and Soakaways	89
4.3.29 Brick Manholes and Chambers	89
4.3.30 Manhole and Chambers Covers and Frames	89
4.3.31 Manhole Steps	91
4.3.32 Access Ladders	91
4.3.33 Jointing Compounds for Chambers and Soakaways	91
4.3.34 Granolithic Facings	91
4.3.35 Reinstatement of Adjoining Surfaces	92
4.3.36 Streams and Watercourses	92
4.3.37 Soakaways and Other Infiltration Features – General	92
4.3.38 Precast Concrete Soakaways	93
4.3.39 Ponds, Wetlands, Detention/Infiltration Basins and Swales	93
4.3.40 Geocellular Storage	93
4.3.41 Permeable Paving	93
4.4 Footways, Footpaths, Cycle Tracks and Service Strips	94
4.4.1 Compaction of Trenches	94
4.4.2 General Preparation	94
4.4.3 Preparation of Formation	95

4.4.4 Soft Spots	95
4.4.5 Precast Concrete Edging.....	95
4.4.6 Sub-Base.....	96
4.4.7 Surfacing.....	96
4.4.8 Pram/Wheelchair Crossings	96
4.4.9 Vehicle Crossings.....	96
4.4.10 Precast Concrete Tactile Paving	97
4.4.11 Precast Concrete Flag Paving	97
4.4.12 Hard Landscaping	98
4.4.13 Statutory Undertakers Covers and Frames	98
4.5 Kerbing and Channelling.....	98
4.5.1 Precast Concrete Kerbs, Channels, Edgings.....	98
4.5.2 Combined Kerb and Drainage Units (CKD)	99
4.5.3 Granite Setts.....	99
4.5.4 Kerb Foundations	99
4.5.5 Kerb Lines	100
4.5.6 Damage to Kerbs	100
4.6 Carriageway Construction (Flexible)	100
4.6.1 Order of Works.....	100
4.6.2 Formation Preparation.....	101
4.6.3 Granular Sub Base Type 1.....	101
4.6.4 Recycled Materials	101
4.6.5 Geosynthetics.....	101
4.6.6 Laying the Sub-Base	101
4.6.7 Asphalt Concrete	102
4.6.8 Hot Rolled Asphalt.....	102
4.6.9 Thin Surface Course Systems (TSCS)	103
4.6.10 High Friction Surfacing	103
4.6.11 Transporting, Laying and Compaction – General	103
4.6.12 Laying Bituminous Materials	103
4.6.13 Compaction of Bituminous Materials.....	104
4.6.14 Bond Between Bituminous Layers.....	106
4.6.15 Statutory Undertakers Covers and Frames	106
4.7 Concrete General	106
4.7.1 Cement Bound Material	106
4.7.2 Cement	106
4.7.3 Aggregates for Concrete.....	107
4.7.4 Water.....	108
4.7.5 Concrete Strengths.....	108
4.7.6 Water Cement Ratio.....	108
4.7.7 Higher Strength Concrete.....	109
4.7.8 Workability of Concrete	109
4.7.9 Admixtures other than Air Entraining Agents	109
4.7.10 Dowel Bars	109
4.7.11 Tie Bars.....	109
4.7.12 Steel Reinforcement.....	110
4.7.13 Curing Compounds	110
4.7.14 Pre-Formed Joint Filler	110
4.7.15 Joint Sealant and Seals	111
4.8 Carriageway Construction (Rigid).....	111
4.8.1 Sub-Base Layer	111
4.8.2 Waterproof Underlay	111
4.8.3 Construction of Formwork	111
4.8.4 Pavement Quality Concrete	112
4.8.5 Air Entraining Agents.....	112
4.8.6 Mixing Concrete	113
4.8.7 Ready Mixed Concrete	113

4.8.8 Workability	114
4.8.9 Transporting and Placing Concrete	114
4.8.10 Concrete Carriageways.....	114
4.8.11 Expansion Joints	115
4.8.12 Longitudinal Joints.....	116
4.8.13 Steel Reinforcement.....	116
4.8.14 Surface Finish	116
4.8.15 Channels and Joints.....	116
4.8.16 Compaction of Concrete	117
4.8.17 Protection of Concrete Bays.....	117
4.8.18 Curing	117
4.8.19 Finished Concrete Carriageway	118
4.8.20 Preparation and Sealing of Joints.....	118
4.8.21 Statutory Undertakers Covers and Frames	118
4.9 Block Paving.....	118
4.9.1 Concrete Blocks and Clay Pavers for Paving	119
4.9.2 Laying Pattern	119
4.9.3 Laying Course for Block Paving.....	119
4.9.4 Laying of the Block Paving.....	119
4.9.5 Compacting Block Paving	120
4.9.6 Joint Filling.....	120
4.9.7 Early Trafficking	121
4.10 Traffic Signs and Roadmarkings.....	121
4.10.1 Traffic Signs	121
4.10.3 Street Nameplates.....	122
4.10.4 Fixing and Erection	122
4.10.5 Road Markings.....	122
4.10.6 Road Studs.....	123
4.11 Street Furniture and Ancillary Items.....	123
4.11.1 Gates and Stiles	123
4.11.2 Salt Bins and Gradients of Road	123
4.11.3 Bollards.....	124
4.11.4 Road Restraint Systems.....	124
4.11.5 Pedestrian Guardrail	125
4.12 Street Lighting	126
4.12.1 Preparation and Planning	126
4.12.2 Street Lighting Specification.....	126
4.13 Soft Landscaping	127
4.13.1 Standard Landscaping – Grass Verges	127
4.13.2 Enhanced Landscape - Trees and Shrubs	127
4.13.3 Planting of Shrubs and Trees in Highway Verges	128
4.13.4 Topsoil	129
4.13.5 Compost	129
4.13.6 Fertilisers	129
4.13.7 Turfing	129
4.13.8 Seeding.....	130
4.13.9 Grass Seed	130
4.13.10 Minimum Grass Verge and Planting Bed Sizes	130
4.13.11 Reinforcing Verges	130
4.13.12 Tree Planting Within Paved Areas	131
4.14 No Dig Policy	131
4.14.1 Construction Works Adjacent to Trees.....	131
APPENDIX A - Tables	132
Table 1 – Industrial Adoptable Roads – Basic Data.....	132

Table 2 – Industrial Adoptable Roads – Widening on Bends 133

Table 3 – Industrial Adoptable Roads – Construction Details (HD 26/06) Pavement Design 134

Table 4 – Road Type Table..... 135

Table 5 –Summary of Pavement Construction for Adoptable Roads..... 137

Table 6 – Road Pavement Foundations..... 142

Table 7 – Granular Bedding and Fill for Flexible Pipes and Land Drains 144

Table 8 – Concrete for Ancillary Purposes to BS EN 206-1:2000 and BS 8500-1:2006 145

APPENDIX B 146

Figure 1 – Residential Adoptable Roads (5.5m wide) - Turning Spaces 146
 146

Figure 2 – Residential Adoptable Roads (5.5m wide) - Turning Spaces 147

Figure 3 – Residential Adoptable Roads (5.5m wide)-Turning Spaces 148

Figure 4 – Industrial Adoptable Roads (6.75m wide) -Turning Spaces 149

APPENDIX C – Notes for Guidance 150

General 150

Layout Plan 150

Layout of Carriageways, Footways and Verges 151

Layout of Sight Lines..... 152

Layout of Houses, Garages and Hardstandings 153

Layout of Concrete Bays and Flexible Bellmouths 154

Locations of Gullies and Lines of Gully Connections 154

Lines of Foul and Surface Water Drains, Sewers, and Manhole Locations 155

Road Longitudinal Sections..... 156

Road Cross Sections 156

Centre Line Chainages 157

Existing Ground Levels 157

Proposed Levels..... 157

Vertical Alignment..... 157

Horizontal Alignment 158

Transverse Profile 158

Longitudinal Sections of Surface Water Drains and Sewers..... 158

Street Lighting 159

Construction Details 159

Submission of Project Engineering Drawings and Documents Required Prior to Commencement of Work 160

Preparation of Drawings for a Section 38/278 Agreement 160

 Project Engineering Drawings:160

 Pink Plan:.....160

Additional Information Required for Section 38 Agreement when Pink Plans etc are Submitted 161

Designers Checklist 162

APPENDIX D – Sampling and Testing Requirements for Adoptable Roads..... 166

 General 166

 Adoptable Housing Estate Roads 166

 Earthworks 168

APPENDIX E - Payment of Costs 169

Works Cost 169

Works Deposit 169

Inspection Fee 169

Traffic Regulation Orders (TRO) 170

Section 228 Notice 171

Proposed Commuted Sums (Also refer to Appendix L of “The Essex County Council Developers Guide to Infrastructure Contributions” – Revised Edition 2015) 171

Section 38 171

Section 278 171

Betterment 172

Standard Commuted Sums for Maintenance..... 172

Legal Costs 174

Licences and Consents 174

Application for Vehicle Crossing under Section 184..... 175

Application for Ordinary Watercourse Consent..... 175

Land Purchase..... 175

Testing of Materials 175

Payment Details..... 175

APPENDIX F- PASSENGER TRANSPORT..... 176

Passenger Transport Infrastructure Standards Guide – Abridged Version 176

The Stop Hierarchy 177

Bus Stop Infrastructure Standards 178

 General Standards 178

 Table D1 – Bus Stop Standards 179

Infrastructure Specification 181

 Real Time Passenger Information 182

 Passenger Transport Priority Measures 182

 Bus Turning Facilities 182

 Maintenance and upkeep during development 182

 Repair 183

Service Access to Developments 183

 Bus service routes through developments 183

 Width of Roads on Bus Routes 184

 Access for Smaller Developments 184

 Temporarily Suspending a Bus Stop 184

Information Sheet for Parties Wishing to Temporarily Suspend a Bus Stop 185

APPENDIX G - MAINTAINABILITY AUDITS..... 187

Requirements 187

 Designers Maintenance Checklist187

APPENDIX H – CONTACT LIST..... 189

APPENDIX I – STANDARD SECTION 38 AGREEMENT 191

AN AGREEMENT made the day of 191

Two Thousand and *** 191**

Part 3..... 202

DEVELOPER/OWNER 202

Form and Date of Security Given 202

 TOTAL202

APPENDIX J - DEPARTURES FROM STANDARD POLICY – DEVELOPMENT MANAGEMENT 208

APPENDIX K - DEVELOPMENT MANAGEMENT ROAD OPENING NOTICE..... 209

 How to Process a Road Opening Notice 209

Appendix L – RECENT UPDATES 212

SECTION 1 - Introduction and Background

1.1 Scope of the Manual

This manual shall apply to all works which are intended to become highway maintainable at public expense, including works within the existing highway relating to new development within the County of Essex.

Adherence to this manual will normally ensure that residential estate roads, industrial estate roads and associated works which are designed in accordance with Essex County Council’s documents, guidelines and drawings will be acceptable to the Highway Authority for adoption.

Where highway works are proposed, it is advisable that discussions are held with the Project Engineer prior to the submission of a planning application and as early in the process as possible.

1.2 Status of the Manual

This is the standard document for Development Management throughout Essex. Essex County Council is the Highway Authority within the County of Essex (excluding trunk roads, for which the Highway Agency is the Highway

Authority, and the Unitary Authorities of Thurrock and Southend-on-Sea).

It should be noted however that, although an application may conform in all respects to the document, it could still be unacceptable and contrary to Policies in the Local Transport Plan and/or Local Development Frameworks because, for example, of its effects on surrounding roads.

Policies on all aspects of transportation are continually emerging and being modified and Designers should ensure they take full account of all relevant and up to date policies in this respect.

It is the designers' responsibility to ensure the most up to date standards, specifications, codes of practice, legislation, guidance notes etc. are used when designing the works. Should there be a significant time lapse between design and commencement of work on site then Essex County Council reserve the right to insist the design is revisited and amended if necessary to comply with the latest relevant details.

Whilst this document is accurate at the time of publication, an up to date version can be found on the County Council website [Adoptions and Land | Essex County Council](#)

All addendums to the document will be given in Appendix L.

The County Council reserve the right to modify, alter and amend the agreed specifications should policies and technical advice change, or special circumstances arise.

1.3 Glossary of Terms

The under mentioned terms are given their full meaning here and will be used in the body of this manual in abbreviated form.

Their meaning to be construed as herein stated:

'Advance Payments Code' (APC) – An APC secures the payment of expenses for carrying out street works in private streets next to new buildings by the Landowner/Developer and to reduce liability on any future purchasers if the street is not completed for any reason.

‘Approval’ or ‘Technical Approval’ – The checking and approval by the Project Engineer of the detailed plans, drawings, specifications and requirements against applicable safety standards and best practice employed or recommended in highway design works.

‘Approval in principle’ (AIP) – The technical approval of structures.

‘BBA Certificate’ – A certificate to confirm that a product has been suitably tested and approved for use by the British Board of Agrément.

‘BS’ – The British Standard Specification current at the time the work is carried out.

‘BS EN’ – The British and European Standard Specifications current at the time the work is carried out.

‘Building Control’ – Duty of a responsible body (such as a building inspector to whom the responsibility has been delegated by an agency or government) to ensure through periodic inspection that the construction work on a site is according to the approved drawings and conforms to the relevant requirements and specifications.

‘Clerk of Works’ (CoW) – The person who will be carrying out the inspection of the works on behalf of the Highway Authority.

‘Client’ – Any Organisation or Individual for whom a construction project is carried out

‘Commuted Sum’ – The commuted sum is the value of the enhanced maintenance or energy that is required over a 15-year period.

‘Completion Certificate’ – (issued for Section 278 works) The certificate issued by the Highway Authority when the works on existing highway land have been completed to the satisfaction of the Project Engineer.

‘Contractor’ – Company or Individual who carries out the actual construction works.

‘Departures from Standard’ (DfS) – Non- compliance with a mandatory requirement of a declared standard.

‘Designer’ – Any person who as part of a business or organisation prepares or modifies designs relating to construction work.

‘Developer’ – The person or organisation responsible for the development.

‘DfT’ – The Department for Transport.

‘Director for Commissioning, Transport and Infrastructure’ – The Director for Commissioning, Transport and Infrastructure for Essex County Council.

‘Distribution Network Operator’ (DNO) – The organisation responsible for the overhead and underground electricity supply network.

‘Drainage Easement’ – An agreement with the Highways Authority and the Landowner to allow access for routine maintenance and repairs to drainage apparatus.

‘ECC’ – Essex County Council.

‘Final Certificate’ (issued for Section 38 works) – The certificate issued by the Highway Authority when the works on private land have been completed to the satisfaction of the Project Engineer.

‘Highway Authority’ – Essex County Council.

‘Independent Distribution Network Operator (IDNO)’ – Develop, operate and maintain local electricity distribution networks.

‘Land Compensation’ – Monetary payment for loss in value to personal property due to highway works covered by the Land Compensation Act 1973.

‘Licences’ – Issued by the Highway Authority permitting the Developer to undertake works within the highway e.g. licence to erect scaffolding.

‘Maintenance Certificate’ – (issued for Section 278) The certificate issued by the Highway Authority at the end of the maintenance period (normally 12 months) when all remedial works have been completed to the satisfaction of the Project Engineer.

‘MCHW’ – The Manual of Contract Documents for Highway Works by the Department for Transport.

‘Minor Works Authorisation’ – The permission to work where the Project Engineer has deemed that a Section 278 Agreement is not required. This is mostly used for minor works only (generally less than £50,000).

‘Noise Regulation’ – A monetary value which is paid by the developer for any noise insulation works that may be required following the works.

‘Part 1 Certificate’ (issued for Section 38 works) – The certificate issued by the Highway Authority when all highway drainage (and all other drainage contained within the highway), all kerbing with foundations, carriageway sub-base, carriageway base course and vehicle visibility sight lines are completed and to the approval of the Project Engineer.

‘Part 2 Certificate’ (issued for Section 38 works) – The certificate issued by the Highway Authority when all works described in the specification and shown in the drawings are completed.

‘Planning Authority’ – Normally the relevant District, Borough or City Council although, in some cases, it will be Essex County Council.

‘Principal Contractor’ – The person or organisation appointed by the Client to be responsible for the execution of the highway works where there is more than one Contractor.

‘Principal Designer’ – The person or organisation appointed by the Client in Projects involving more than one Contractor.

‘Project Engineer’ – The authorised representative for the Director for Commissioning, Transport and Infrastructure who will manage the scheme and provide technical advice and assistance on behalf of the Highway Authority. This person may change as different stages of the process are reached.

‘Relaxation’ – A permitted variation from the mandatory requirements of a declared standard.

‘Resident Project Engineer’ – The authorised representative for the Director for Commissioning, Transport and Infrastructure who will manage significant

highway schemes and provide technical advice and assistance on behalf of the Highway Authority. This person will be primarily based on the works site.

‘Sustainable Drainage Systems’ (SuDS) – A sequence of management practices and control structures designed to drain surface water in a more sustainable manner than most conventional techniques.

‘Traffic Regulation Order’ (TRO) – A TRO is required to support most regulatory signs (i.e. – no right turn, no entry, no loading, waiting restrictions) and other restrictions such as speed limits, bus lanes and mandatory cycle lanes as stated in the Traffic Signs Regulations and General Directions 2016.

‘Unilateral Undertaking’ (UU) – A one sided covenant on the part of the Developer to undertake works or provide payment.

‘Works Licence’ – This is the term given to the permission to work that forms part of a Section 278 Agreement. A Works Licence application form is always attached to the back of every agreement.

1.4 Approval Process

Evidence of a relevant Planning Consent is required in most cases before the Highway Authority is able to give technical approval. This will normally involve providing the Highway Authority with a stamped, approved copy of the planning consent notice, conditions and approved plan.

All schemes on the existing public highway should have had an independent Stage 1 Road Safety Audit at the planning stage and this should be included with your submission.

Technical approval of drawings and specifications/materials must be obtained from the Highway Authority prior to commencement of the highway works.

The remainder of this chapter outlines in more detail the process that needs to be followed in order to introduce your scheme in the most efficient manner.

1.5 Other Relevant Documents

As a general rule, the codes of practice etc. current at the time of the development shall be used where appropriate. Where the Developer is aware that a document has been updated or replaced, a check shall be made before it is used.

The following documents have been referred to in the preparation of this manual.

- i. The Essex Design Guide - Essex County Council
- ii. Design Manual for Roads and Bridges (DMRB) – DfT
- iii. DMRB CD123 - The Geometric Design of at Grade Priority and Signal-Controlled junctions
- iv. National Joint Utilities Group (NJUG 1) - Guidelines on the Positioning and Colour Coding of Underground Utilities Apparatus 2018
- v. National Joint Utilities Group (NJUG 2) - Guidelines on the Positioning of Underground Utilities for New Development Sites 2013.
- vi. National Joint Utilities Group (NJUG 4) - Guidelines for the Planning, Installation and Maintenance of Utility Apparatus in Proximity to Trees 2007
- vii. Water UK Sewerage Sector Guidance SSG
- viii. Construction (Design and Management) Regulations 2015 (CDM 2015) – Health and Safety Executive
- ix. Managing Health and Safety in Construction – CDM 2015 – L153 Guidance on Regulations
- x. Guidance on the Use of Tactile Paving Surfaces – DfT
- xi. Standard Folio Drawings - Essex County Council (currently under review, to be republished)
- xii. Manual of Contract Documents for Highway Works (MCHW) – DfT
- xiii. Interim Advice Notes (IANs) - DfT
- xiv. The Traffic Signs Regulations and General Directions 2016 (TSRGD 2016) – DfT
- xv. Sustainable Drainage System (SuDS) – SuDS manual by The Construction Industry Research and Information Association CIRIA-C697 – (Cambridge City guide)
- xvi. The Equality Act 2010 (EA) – HM Government Legislation
- xvii. Designing for Cyclists, A Guide to Good Practice - Essex County Council
- xviii. Temporary Traffic Management, Traffic Signs Manual Chapter 8 –

DfT

- xix. Safety at Street Works and Road Works - A Code of Practice – DfT
- xx. New Roads and Street Works Act 1991 (NRSWA) – DfT
- xxi. NRSWA Specification for the Reinstatement of Openings in Highways, A Code of Practice (April 2010) – DfT
- xxii. Manual for Streets (March 2007) – DfT
- xxiii. Standard Details and Specifications for Highway Tree Planting – ECC
- xxiv. Technical Approval of Third Party Structures – ECC
- xxv. Street Lighting Development Management Specification – ECC
- xxvi. Local Transport Note Policy LTN 1/20 Cycle Infrastructure Design – DfT
- xxvii. The Essex County Council Developers Guide to Infrastructure Contributions – Revised Edition 2015

1.6 Advance Payment Code (APC)

Before the technical process commences, you may receive communication from Essex County Council on the APC. The ‘Advance Payments Code’ (Sections 219 to 225 of the Highways Act 1980) applies throughout the County of Essex. This code has two objectives:

- 1) Safeguarding householders from potential road charges.
- 2) Ensuring that before building work starts a sum of money will be deposited with the Street Works Authority (ECC) by the land owner or the person erecting the buildings (if different).

This reduces the liability on any future purchasers if their street is not finished for any reason. When development has reached a certain stage, frontages (*as defined below*) are able to require the carrying out of street works to facilitate the adoption of the street.

APC’s should be levied on all buildings which will have a frontage upon what is at that time a Private Street (*a frontage in this context simply means that some part of the boundary of the building abuts the street*). A Private Street for APC purposes refers to new or proposed estate roads or other roads which are constructed and from which dwellings, flats etc. take access but which are at that time not the subject of any adoption agreements.

The fact that Developers may have indicated their intention to enter in a Section 38 Agreement does not absolve them from their responsibility to pay sums due under the Advance Payments Code.

Essex County Council has resolved that the APC will generally **not** be applied to a private street that is capable of serving five or less buildings. The reasoning for this is that these streets do not constitute sufficient public utility and therefore are not suitable for adoption.

However, the APC **may** be applied to a private street that has five or less buildings if it is capable of taking further development in the future which would lead to more than five buildings.

The Building Control department of the local authority is required to provide details of all sites where building regulations have been approved which could be subject to the Advance Payments Code. Case law has confirmed this position.

Building Control is obliged to send the Highway Authority details of the Building Plans deposited with them within one week of approval.

The County Council has six weeks from building regulations approval in which to calculate the sum of the APC and to serve the APC notice on the person who deposited the plans.

***Note:** An APC Reduction Notice is a mechanism whereby if substantial works have been completed to the Highway Authority's approval e.g. carriageway construction, the Developer can apply for a reduction to the original APC amount.*

The Code applies to private streets, i.e. ways which are not highways maintainable at the public expense. **If a Section 38 Agreement relevant to those plots is in place before building work has commenced, then the APC will not apply.**

If the Developer wishes to keep the street private and have their APC deposits returned, then it will be necessary to enter into a Town and Country Planning Act 1990 Section 106 Unilateral Undertaking that obliges them to ensure that all purchasers are party to a management company maintaining

the private road.

Householders must also be advised that the Highway Authority will have no obligation to make the road up and maintain it at public expense.

It is a criminal offence for the Developer or the person erecting the buildings (if different) not to secure the sums required to be paid under the Code before commencing construction of buildings.

Further information on the Advance Payments Code is available on request from the Project Engineer.

1.7 Maintainability Audits

The future maintenance requirements of new estate roads intended for adoption presents a significant liability on the financial and operational resources of the Highway Authority.

The Highways Act 1980 entitles us to seek expenses for enhanced maintenance and this mechanism is called 'commuted sums.' This allows greater flexibility to adopt non- standard layouts and materials without placing additional pressure on our maintenance budgets. The commuted sum is the value of the enhanced maintenance or energy that is required over the commuted sum period for further information on commuted sums, see Appendix E.

It is the responsibility of the designer to carefully consider future maintenance and maintainability requirements and factor these into the design at an early stage and throughout the design process.

Considerations:

- 1) The elements of layout design and the use of materials to maximise whole life expectancies should be considered at an early stage in the design in order to ensure the ease and cost effectiveness of their future maintenance and to meet the obligations of the CDM Regulations. The frequency of maintenance that will be required should also be considered. It is important that early and ongoing consultation takes place with the Highway Authority.

- 2) It is not intended to stifle creativity in the design of schemes or the selection of materials. Designers are encouraged to seek out and propose new materials, products and design/construction techniques, however full consideration and evaluation of their future maintenance implications must be evidenced. Also, materials and design features should be chosen to complement and enhance the local character of the existing area.
- 3) An important aspect of designing for maintainability is the placement and co-ordination of underground services. Maintenance and replacement implications should be assessed and considered in the design of such services, with Statutory Undertakers being consulted early on in the design process to ensure future maintenance is fully considered.

Note. For further information see Appendix G.

1.8 Types of Legal Agreements

To carry out any work in the public highway, approval must be obtained from the Highway Authority. This section of the document sets out the processes and legal agreements involved in obtaining Highway Authority approval for Developer funded highway works.

Section 38

Where development involves the construction of new estate roads to provide access from buildings within the development to the highway network, the owners of the land can enter into a Legal Agreement with the Highway Authority under Section 38 of the Highways Act 1980 to have it adopted as publicly maintainable highway. The Agreement can include the developer(s) of the land upon which the estate road is to be constructed (if different to the owner). The County Council will normally require a Section 38 Agreement to be supported by either a cash deposit or for there to be an appropriate surety, underwriting the Agreement to ensure that any costs which may arise to secure completion of the roadworks are met in the event that the County Council has to call on the bond to complete the works.

An approved Surety can be a party to the Agreement and will be liable for the entire cost for Essex County Council to complete the proposed works,

as calculated by the Highway Authority based on the approved drawings.

The Section 38 Agreement will identify payments received by the Council by way of the Advance Payments Code (APC) and provides for their repayment with accrued interest. It is not the Council's normal practice to enter into a Section 38 Agreement with a landowner where that landowner has failed to make payments to or lodge security with the Council under the APC relating to commenced buildings fronting any street intended to be included in the proposed Agreement.

Only when the landowner, the surety and the County Council have sealed the engrossments of the Agreement should house building works start unless deposits have been made or a temporary Bond provided. If building works starts before this stage, then technical approval must be provided to prevent abortive works and the full inspection fee will be required. When the Agreement has been completed it will be advised to the District Council and declared as a local land charge in connection with local search enquiries.

The Developer will need to confirm to the Highway Authority the adoption arrangements for the drainage systems.

For foul and surface water drainage measures, written evidence of approval from the relevant Water Authority will be required where appropriate before the Section 38 Agreement can be signed

The County Council will normally consider adoption of estate roads provided that:

- All payments have been made under the provisions of the Advance Payments Code
- All work is completed in accordance with the relevant specifications, the British Standards and this Manual
- All the works have been completed to the satisfaction of the Project Engineer

Areas that may be offered for adoption include:

- Carriageways
- Turning areas
- Highway drainage

- Bus laybys
- Cycle tracks
- Footways and footpaths
- Verges (where agreed)
- Visibility splays

Note: *Amenity areas, private car parking areas, play spaces and other open spaces not necessary for highway purposes shall be excluded from a Section 38 Agreement and are not areas the Highway Authority would wish to adopt. Developers need to make alternative arrangements to secure their future maintenance.*

To look at the terms of a standard Section 38 Agreement please refer to Appendix I

Section 106

Section 106 of the Town and Country Planning Act 1990 (as amended) is a way to secure a financial contribution from the Developer for highway improvements as mitigation for development.

It can also be combined with a Section 278 agreement to provide works within an existing highway. However, where this is used, it is the same mechanism so please refer to Section 278 for further information.

Section 228

Where there is no Section 38 Agreement in existence between a Landowner and the Highway Authority providing for the making up and eventual adoption of any way, it may still be possible for a highway to be offered for adoption or for the Council to adopt it under the provisions of Section 228 of the Highways Act 1980. It may, for instance, not be possible to enter into a Section 38 Agreement because ownership of land is unknown or disputed or the landowner can show only a possessory title. In the case where street works have been satisfactorily carried out, the County Council as street works authority may under the provisions of Section 228 of the

Highways Act 1980 declare the street to be a highway which is maintainable

at the public expense and post notices in a prominent position in the street to that effect.

In such instances, the Developer upon application shall furnish twelve copies of a scaled plan to the Highway Authority which shall show all areas for adoption marked in yellow, together with proposed boundaries.

Adoption is in effect on the expiration of one month from the day on which the notice was first so displayed unless:

- 1) The owner of the street or, if more than one, the majority of the owners' object by notice to the street works authority, and
- 2) The Council does not apply to and get from the Magistrates' Court an order overruling the objection.

A Developer should note that because of the possibility of objection being made by an owner of land forming the subsoil of the road, Section 228 under the Highways Act 1980 **offers no guarantee in respect of eventual adoption by the County Council.**

Upon a way being declared a highway which is maintainable at the public expense, monies held by or securities lodged with the County Council under the Advance Payments Code would be repaid to or released in favour of the owners of the buildings fronting the street the subject of the notices given under the code requiring the payment or alternatively repaid to the payer of the sum following a consultation of the owners of the street.

It should be noted that where the land in question is already adjacent to existing Public Highway then Section 72 of the Highways Act should be used.

Section 278

Section 278 of the Highways Act 1980 provides for a financial contribution to be paid to the highway authority for highway works to be undertaken although it is commonly used to provide for the Developer to carry out the Works on behalf of the Highway Authority within the existing highway.

The County Council will normally require such an Agreement to be

supported by either a cash deposit or an appropriate bond secured to ensure that any costs which may arise to secure completion of the road works are met other than at the expense of the Highway Authority.

Licences are often involved in Section 278 works – these could include an overhang licence, licence to cultivate, hoarding licences, private apparatus in the highway and drainage easements. These are explained in more detail in section 1.9.

Section 72

Section 72 of the Highways Act 1980 enables land adjoining a public highway to be dedicated by its owner to the public for the purpose of widening of the highway. Under the same section, the Dedication can also be requested by the Highway Authority for the purpose of footpath creation under Section 25.

Typical situations where highway widening can be done under this section are as below

- Bus Shelter Hardstanding
- Traffic Signal Controllers
- Lamp Columns
- Visibility Splays
- Provide a clear highway boundary
- Turning heads
- Widen footways/cycleways or provide new footways/cycleways
- Laybys
- Other street furniture/highway infrastructure that cannot be located within the existing highway

Minor Works Authorisation

In some instances, for minor works the Project Engineer may consider a minor works authorisation in lieu of a Section 278 Agreement.

A minor works authorisation does not require the involvement of legal teams and is an agreement that is signed by the Developer and includes a list of Terms and Conditions. The County Council still requires the minor works authorisation to be supported by a cash deposit to ensure that any costs which may arise to secure completion of the road works are met.

It should be noted that a cash deposit for the minor works authorisation is not held in an interest-bearing account.

The maintenance period for a fee is at the discretion of the Project Engineer.

Section 171 Road Opening Notice for Trial Hole Investigation Works

The CDM Regulations 2015 place responsibilities on all those who can contribute to improving health and safety, including clients, designers, and contractors. These responsibilities relate to planning, management, design, and co-operation between those involved in the project. Risks should be properly managed by action during the design, planning, and execution phases of the project.

Under the principles of the CDM regulations, investigatory trial hole works play an important role in mitigating risk in terms of both producing safe and suitable designs that are fit for purpose and operationally, which can significantly aid the safe and smooth planning of the works.

The early determination of accurate location and depths of utilities and ground conditions early in the process can assist the designer under their obligations to design out/reduce risk.

The S171 Road Opening Notice Form enables an application to be made to undertake trial holes within the public highway at an early stage e.g., design and assists in meeting the obligations of Duty Holders under the Regulations. This process assists in determining the depth and location of utilities e.g., via trial holes/slip trenches etc and assists in the safe planning of the works and should be considered for each project on a site-specific basis.

The relevant forms can be downloaded under the Essex Highways Website:- <https://www.essexhighways.org/applications/dm-section-171-road-opening-notice>

1.9 Other Agreements

Section 50 of the New Roads and Street Works Act 1991 - This is a Licence which allows for private apparatus to be placed in the public highway and be thereafter maintained by the licence holder.

Note: It must be obtained retrospectively if any uncharted apparatus is discovered.

Section 176 of the Highways Act 1980 – This is a licence which deals with the construction of private bridges over the public highway.

Section 177 of the Highways Act 1980 - This is a licence which deals with the construction or alteration of buildings which overhang the highway maintainable at public expense.

The oversailing of the public highway is not to be encouraged however where there is no option then the minimum headroom should be 4.2 metres. Where the oversail is directly over carriageway then the minimum headroom should be 5 metres.

Section 178 of the Highways Act 1980 – This is a consent which deals with the attachment of banners, rails, lights, shop signs to buildings which overhang the highway maintainable at public expense. This section is also used to give temporary consent for cranes to oversail the public highway.

Section 179 of the Highways Act 1980 – This is a consent which deals with vaults, arches or cellars which run under the highway.

Section 247 of the Town & County Planning Act 1990 – This allows the developer to remove highway rights from the public highway after a statutory consultation period and prior to any commencement of the development. There must be a planning consent which highlights the change of use.

Section 116 of the Highways Act 1980 – Under certain circumstances, this allows highway rights to be removed. This can only be processed by the Highways Authority and is used where the land is enclosed or there is no planning application. After a statutory consultation period, the decision is made by the Magistrates Court.

Easement - an easement is implemented under the Land Registration Acts 1925-2002. This allows the Highway Authority access onto private land to maintain, inspect and repair apparatus belonging to them.

Note: A similar type of agreement will be required for any statutory authority apparatus installed within private land and contact shall be directed to the relevant utility company.

FOR ADDITIONAL INFORMATION ON THE DRAWING REQUIREMENTS FOR LEGAL AGREEMENTS SEE APPENDIX C. COPIES OF ALL MODEL AGREEMENTS ARE AVAILABLE ON REQUEST.

1.10 Payment of Costs

For costs associated with private highway works, please refer to Appendix E.

1.11 Compensation

Under the **Land Compensation Act 1973** an assessment will be made where it is felt that personal property has suffered a loss in value due to the highway works, and it is considered that claims for compensation under the terms of the act are likely to be received by this authority. A bond or deposit to cover the estimated cost of noise and land compensation liability will be payable by the Developer.

Under the **Land Compensation Act 1973 Section 19(3)** compensation payments are denied to the Developer if a highway does not become maintainable at the public expense within three years of opening to traffic. Case law has ruled that breach of human rights is established if there is a failure to secure adoption under agreements with Developers within that period. Intent of legislation is that 3 years is a reasonable period within which adoption should be secured.

Protection of Residents from Excess Noise

The Noise Insulation Regulations 1975 require the Highways Authority to offer noise insulation or grants to occupiers of dwellings subjected to noise at or above the specified level due to the use of a new or altered highway. Any agreement contains a clause requiring you to indemnify the Highway Authority (protect the Highway Authority from legal responsibility) against the full costs of any payments we make under these regulations.

The Regulations require us to publish a noise map within 6 months of the

opening of the road which identifies eligible properties who can then apply to us for noise insulation measures. The type of measure that can be offered is very restrictive and it is not common for a resident to pursue compensation on this basis.

1.12 Technical Approval Process

In the first instance all documents for highway approval should be submitted to the Senior Engineer for that district – names and addresses are provided in Appendix H - list of contact details. The technical approval process is applicable to all types of legal agreements.

Time Scale

The Developer and their Designer should allow a minimum of **four months** for the formal acceptance of the design. However, in the majority of cases it is found that considerably more time is required, and it is suggested that a minimum of **six months** be allowed for the process. Where structures are involved more time is required.

The timely submission of good quality drawings and documents will assist in speeding up the process. However, the resubmission of drawings and documents before comments on the previous submission have been provided can cause confusion and delay in the process.

Identification

All drawings, documents and calculations should be clearly identified by the scheme title and given a unique drawing or reference number. A drawing or document revision numbering system should also be applied with changes between revisions clearly identified, such as the use of margin bars and/or bold text in documents. ECC will assign a reference number of their own to the scheme which should be quoted on all future correspondence. This will start as a prefix DM/xxx/xx.

One paper copy of the submission is normally required in addition to an electronic copy in the format to be agreed with the Project Engineer.

For schemes involving traffic signals and/or structures, refer to separate guidance documents on the website. This is likely to involve further sets of drawings. <https://www.essexhighways.org/uploads/downloads/development-management/eh-its-design-and-installation-guidance-for-developers-v9.pdf>

<https://www.essexhighways.org/uploads/downloads/development-management/infopack-eurocode-v14-december-2021.pdf>

Design Standards

The design speed used for the design must be specified. Where not previously agreed by the Highway Authority the reason for the choice of design speed should be given by reference to existing and proposed speed limits, 85th percentile speeds, etc.

For junction specification the design standards used should be those applicable to the major road.

The following is an indication of the type of information that should be provided:

Layout

A general arrangement plan covering the extents of the entire scheme/development should be provided at a recognised scale.

All visibility sight lines, drainage, signage, structures, cable runs, etc that may affect the highway boundary should be shown on the same drawing.

The Developer must be aware that the proposed highway boundary shown on the detailed design may be subject to change during the construction phase of the development.

Survey Data

Detailed design should be based on a topographical survey carried out on site; reliance should not be made on Ordnance Survey plans.

Levels should be to Ordnance Datum with Ordnance benchmark position and level shown on the general arrangement plan.

The survey should show existing surface finishes, accesses, frontage of new and existing buildings facing the highway in the vicinity of the site, all street furniture, manholes, road markings, service company covers, overhead cables, etc. Levels should be given for existing accesses, both pedestrian and vehicular to 5 metres from the highway boundary if possible.

Geometric Design

Sufficient information must be given to enable all aspects of the design to be checked. For alignments all tangent points, transitions and radii be specified.

All lane, carriageway, footway, cycle track and verge widths, traffic island and splitter island dimensions junction radii, table and hump dimensions etc should be specified.

Location of all dropped kerbs for existing and proposed pedestrian and vehicle crossings, tactile paving, guard-rails, etc should be specified. Level information should be provided at all changes in cross section gradients.

Sufficient level information should be provided outside the highway boundary to be able to determine the flow of surface water. This may be in the form of levels, contours or gradients.

Contour drawings should be provided for all roundabouts and other junctions. Contours may be required for simple junctions where drainage is likely to cause problems.

Clear and understandable vehicle track drawings should be provided for all permitted movements for all expected vehicle types.

Visibility

The full extent of all visibility splays at junctions should be shown. Where these may be affected by the vertical profile, longitudinal sections should also be provided.

On tight radius curves where the forward visibility falls outside the proposed back of verge or footway the visibility curve should be shown.

Where the road alignment or roadside features may limit the visibility to traffic signs then the visibility lines should be shown.

At traffic signals all visibility requirements, as specified in TD50/04 should be shown.

Please refer to Appendix C for full Notes and Guidance on the preparation and submission of Project Engineering Drawings for new roads/residential schemes.

Drainage

ECC has a policy of not adopting Sustainable Drainage Systems (SuDS) unless exceptional circumstances prevail. The developer must be able to demonstrate that is not possible for the SuDS to be adopted by a water company, with design changes if necessary.

The location of all existing and proposed gullies, pipe runs, chambers, gullies, ditches, headwalls, outfalls, etc should be shown and clearly differentiate between those to be adopted as highway drains and those to be adopted as public sewers by the water authority.

Calculations should be provided for gully spacing and the highway drains. Where the highway drains form part of an existing system then the calculations should cover the complete system from its head to discharge point.

Drainage and manhole schedules should be provided giving details of all pipe diameters, gradients, levels, cover, chamber invert and cover levels etc should be provided.

The retained height and dimensions of all headwalls should be provided. If the design does not accord with ECC standard folios, then calculations etc should be provided as required for structures.

Copies of all consents from the water authority and any easements restricting work on or above the asset should be provided.

It is likely that Sustainable Drainage Systems (SuDS) will form part of the drainage strategy for your site and should be implemented and integrated from the beginning of the design phase and preferably be included in the Development Plan or Master Plan for the site. The interaction between the highway system and the wider site drainage system needs to be shown on the submitted drawings. We will need to understand how each element will be maintained.

Typical examples of SuDS:

- Swales
- Retention ponds
- Wetland basins
- Filter drains

Earthworks

Where substantial earthworks are required a copy of the geotechnical survey together with a copy of the Consultants recommendations should be provided.

Details of capping material and depth is to be specified. It is accepted that the final decision on capping depth may be dependent on tests carried out after excavation or fill.

Details of all cutting and embankment slopes, fill material, etc should be specified. Where ditches are involved sections and levels should be provided.

Pavement Design

Surfacing depths and the specification of all materials shall be provided as contained in this Manual.

On roads with high traffic flows - details of design life, millions of standard axles and supporting calculations shall be expected.

Construction Details

Construction details and specification of materials for all aspects of the works should be provided. This should include the construction of such

items as: carriageway, footways, vehicle crossings, tactile paving, kerbing and edging details, drains and gullies, tables, humps, chevron paving, street furniture including foundations, longitudinal and transverse pavement tie-ins, etc. Recyclable materials should be specified where possible.

Traffic Signs and Road Markings

All traffic signs, road markings, road studs, etc should be shown referenced to The Traffic Signs Regulations and General Directions 2016.

The location of all signs should be shown, especially for large signs such as advanced direction signs.

A schedule of all signs should be provided which should include such information as size, x-height, mounting height, materials, post dimensions, foundation details, illumination, etc. For advanced direction and direction signs the layout and destinations should be shown.

The materials to be used for all road markings, studs, etc should be specified.

Structures

All calculations, drawings and certificates should be provided as specified in the Essex County Council *Technical Approval of Third Party Structures – Guidance Note for Applicants*. This document can be viewed on the website <https://www.essexhighways.org/uploads/downloads/development-management/technical-approval-of-third-party-structures-guidance-for-applicants-v15.pdf>

Safety Fences and Other Street Furniture

Details of materials to be used, foundations, dimensions, etc of all street furniture, safety fences, posts, bus stops, environmental barriers and other street equipment should be specified.

The requirement for passively safe signposts or traffic signal poles shall be discussed with the Project Engineer and clearly indicated on the drawings.

Street Lighting and Illuminated Signs

The location of all street lighting columns and illuminated signs (including passively safe apparatus) shall be clearly indicated on the street lighting drawing.

The specification for lighting columns, lighting units, and circuit diagrams shall be provided as per the ECC Street Lighting Development Management Specification.

This document can be viewed on the website

<https://www.essexhighways.org/adoptions-and-land#docs>

Bus Stops – (See also Appendix F – Bus Infrastructure)

All bus shelters and associated infrastructure shall conform to the requirements of the ECC Infrastructure Standards and Developer Guidance which is available from the Passenger Transport Team of Essex County Council or on request to the Project Engineer.

Traffic Signals

Traffic signal drawings and calculations should be provided in accordance with the Essex County Council *Traffic Signal Design and Installation - Guidance Note for Developers*. This document can be viewed on the Essex County Council website.

<https://www.essexhighways.org/uploads/downloads/development-management/eh-its-design-and-installation-guidance-for-developers-v9.pdf>

The Developer should be aware that only equipment type approved by Essex County Council is acceptable.

Site Limits and Highway Boundary

The limit of the works, existing and proposed highway boundaries and any easements for land ownership or other purposes should be clearly shown.

Statutory Undertakers

The location and depth of all existing service company plant and proposed diversions shall be shown. The location, dimensions, depth and number of

all ducts should be provided. Traffic Regulation Orders

The processing of traffic orders will normally be carried out by the Highway Authority. The Developer needs to ensure that all traffic regulation orders are clearly shown on the drawings so as they will be identified when the purchasers conduct a search e.g. waiting restrictions.

Landscaping

The species of plants and locations of all landscaped areas within and adjacent to the highway and highway drains shall be provided. Details of any proposed root protection system shall also be provided.

Road Safety Audit

Stage 2 Road Safety Audit(s) and any subsequent road safety audits will be carried out by Essex County Council. A designer's response is required to address all items raised in the Stage 2 Road Safety Audit.

Please see Appendix J for the Departure from Standards process

On Section 38 sites, a road safety audit will be required where local distributor roads are created. However, if the layout contains features which are not explicitly covered by the design guidance or if any proposed cycle facilities interface with existing highway network, then it is likely that an audit will be required on sites for Essex Design Guide Road Types A-D.

The Developer or his Designer should identify all aspects of the design for which relaxations or departures from the standards or policies are required. This will be highlighted on an exception report. For each relaxation or departure, the location, relevant standard, required relaxation or departure and why the relaxation or departure is required should be clearly given. This information will then be used by the Project Engineer, when completing an exception report, where required.

1.13 Formal Technical Approval

The Highway Authority will advise the Developer in writing of his approval to the design. If the works are not commenced within twelve months of this

approval the approval will lapse and the Developer will need to resubmit the design for approval.

If the works have not commenced within six months of the approval being given and new standards relevant to the works have been issued, the Highway Authority may review the submission and request alterations be made to the design to comply with such amendments.

1.14 Pre-Construction Requirements for a Section 38 Agreement

When technical approval has been granted the Developer must notify the Highway Authority with 14 days' notice of the intention to start works.

- No inspection will be undertaken until the following is in place:
- The Section 38 legal agreement has been signed, unless agreed with the Project Engineer.
- The initial inspection fee has been paid.
- The Project Engineer has been advised of the Principal Contractor.
- A programme of construction works has been provided to the Project Engineer.
- Emergency contacts have been provided.
- Relevant notices served in accordance with NRSWA if any works are on the existing public highway.

** If works within a Development site have begun before signing of a Section 38 Agreement then the remainder of the inspection fee will be due immediately so that relevant site inspections can be made. This will be at the Project Engineer's discretion and it must be made clear that without a signed Agreement and/or Technical Approval any works carried out are at the Developers risk **

The Clerk of Works who will be carrying out the inspection of the works on behalf of the Highway Authority will notify the Developer of the site inspection procedures required throughout the duration of the works.

It is the Developer's duty to fully comply with these procedures and to liaise

with the Clerk of Works and/or appropriate office of ECC (see Appendix H).

1.15 Pre-Construction Requirements for a 106/278 or Minor Works Authorisation Agreement

When technical approval has been granted the Developer must apply using the form contained in the legal agreement to the Highway Authority for the issue of a Works Licence. For work permits, an application form can be requested from the Project Engineer.

The Works Licence will not be issued until the following are in place:

- All legal agreements have been signed.
- All bonds, fees, deposits, etc have been paid.
- The Project Engineer has seen written proof that the Developer has notified the Health and Safety Executive (Form F10 – Notification of Construction Project) that they will be acting as the Client for the works for the purposes of the Construction (Design & Management) Regulations 2015 *
- The Project Engineer has been advised of the Principal Contractor.
- Evidence that the Principal Contractor has public liability insurance to a value of at least £10 million.
- A programme of construction works has been provided to the Project Engineer.
- A construction phase plan including emergency contacts has been provided.
- Evidence of a programme of consultation.
- Relevant notices served in accordance with NRSWA.
- Traffic Management Plans and assessment form

** One or more of the Clients may agree in writing to be treated for the purposes of these Regulations as the only Client or Clients (Regulation 4(8) (a)) **

The Clerk of Works who will be carrying out the inspection of the works on behalf of the Highway Authority will notify the Developer of the site inspection procedures required throughout the duration of the works. It is the Developer's duty to fully comply with these procedures and to liaise with the

Clerk of Works and/or appropriate office of Essex County Council (see Appendix H).

The Developer is required to advise the Project Engineer of the start of works 14 days prior to commencement on site.

1.16 Other Pre-Construction Requirements

This section gives guidance on the requirements of the Highway Authority prior to commencing works and during the construction and maintenance phases.

The Developer shall be required to arrange both a pre-construction meeting and site safety induction for the Highway Authority representatives before commencing the works.

New Roads and Street Works Act 1991 (NRSWA)

The Developer is responsible for ensuring that all relevant notices are served in accordance with NRSWA 1991. It is this process that books the road space for the Developer to enter the highway to carry out the approved works.

However, no works will be permitted in the highway until the Works Licence/minor works authorisation has been issued.

Works Category (working days)	Notification Period (working days)
Minor Notice	3 working days
Standard Notice	Up to 10 working days
Major Works	3 months

Note: Any works requiring traffic orders are deemed to be major works irrespective of the duration.

A form is available online from <https://www.essexhighways.org/dm-road-opening-notice> Once completed this is then returned via the email address – dm.busman@essexhighways.org.

Streetworks Site Consultant	Districts Covered
Mr Ben Runham ben.runham@essexhighways.org	Braintree Colchester Tendring Chelmsford Maldon
Mr Ray White raymond.white@essexhighways.org	Uttlesford Harlow Epping Forest Brentwood Basildon Castle Point Rochford

The co-ordinators will be able to advise if your works conflict with any other works being carried out in the area.

See Appendix K for further information and link to forms

Liaison with the Public and Other Bodies

The Developer is required to give at least two weeks' notice in writing to the occupiers of all premises directly affected by the works and those whom in the opinion of the Highway Authority may be affected by the works.

The Developer should advise the emergency services of the works.

The level of notification of the scheme will vary depending on the duration and degree of disturbance to the highway. The consultation may include such items as leaflet drops, newspaper advertisements, temporary advanced signing (2 weeks notification required) and meetings with local Town and Parish Councils. The Project Engineer can advise on the level of

notification of the scheme required and is available to check any correspondence before sending to the public.

Copies of all correspondence should be sent to the Project Engineer.

Emergency Contacts

The Developer is required to nominate a member of the site management team as an emergency contact point and details shall be displayed on site. In addition to this the Highway Authority requires a 24-hour contact number for the site.

1.17 Construction

Protection of the Public

At all times the Developer is responsible for ensuring the safety of all users of the Highway from the commencement of the works until the issue of the Completion Certificate.

The Developer must ensure that at all times the site is adequately protected, road works signage is provided in accordance with Chapter 8 of the Traffic Signs Manual, all areas open to the public are kept free of mud or other hazardous substances and minimise any nuisance from noise or dust.

A record of all complaints received from the public and actions taken must be maintained on site. This record must be available for inspection by the Highway Authority.

Construction (Design and Management) Regulations 2015 (CDM 2015)

It is a legal requirement that the Developer must comply with the CDM 2015 Regulations. The Developer as Client is responsible for appointing a Principal Designer and a Principal Contractor. The Developer shall therefore take on all Client and Designer duties under the CDM Regulations.

The Developer shall ensure projects are properly managed at all times and **MUST** coordinate all measures relating to the health and safety of people affected by their project.

Supervision Responsibilities

The responsibility for day to day supervision of the construction works for

Section 38, Section 278 and minor works authorisation rests with the Developer and their Contractors. The Development Management Teams role is to inspect the works to ensure that they are being constructed in accordance with the approved specification and other development specific requirements. The Development Management Team will not issue instructions to the Developers Contractor, rather advice concerning compliance with the approved specification. Amendments to the specification must be agreed by the Client and issued by the Principal Designer.

The site presence of a Development Management representative does not absolve the Client, Principal Designer or Principal Contractor from supervising the works and making sure that they are carried out in a safe and proper manner.

Inspection

Inspection of the works will be carried out by the Highway Authority. The level of inspection will be determined by the Senior Clerk of Works and will normally be on a visitation basis. Larger sites may have resident staff.

The Developer is required to give the Project Engineer, Clerk of Works and any other duly authorised person free access to the site to enable the works and materials to be inspected. This includes access to any premises where materials are stored or being prepared or manufactured.

Inspection hours will generally be within normal working hours Monday to Friday excluding Bank Holidays. Details of any works to be carried out outside of these times should be given to the Inspector so a decision can be made if attendance is required.

Inspection Notification

14 working days	Before commencement of the works on site.
3 working days	Before commencement of any road construction.
2 working days	Response to design changes.
24 hours	Any other inspections including the covering up of works.

The Project Engineer may request the Developer to carry out any tests deemed necessary and to be tested by a UKAS (NAMAS) laboratory. Any material deemed unsuitable will be rejected. All costs of testing and

replacement of materials to be borne by the Developer. Any rejected materials must be removed from site or stored separately.

Hours of Working

The hours of working may have been agreed with the Planning department earlier in the submission process but must be agreed with the Street Works co-ordinator who may restrict hours of work depending on the function of the street.

Provisions for Resident Engineers

Where the Project Engineer has determined that there shall be resident staff, or the level of attendance is 50% or greater than the Developer must provide separate accommodation and facilities for the staff specified by the Project Engineer.

Typical provision may include accommodation, office furniture and equipment, separate toilet facilities, provision of telephone, internet access, provision of all consumables, provision of all relevant documents, regular cleaning, payment of all costs incurred etc.

On all sites a copy of the approved drawings and documents should be available for the use of the Clerk of Works.

Design Changes

The Developer is responsible for submitting proposed changes to the design that may be required that result from unexpected features on site or to rectify defects in the design, for the approval of the Project Engineer.

Traffic Signals

The Developer is responsible for informing the Project Engineer regarding all matters concerning the installation, testing and commissioning of traffic signal equipment.

Utilities

The Developer is responsible for issuing all notices to the Utility companies and arranging any required diversions.

All costs are the responsibility of the Developer. Unless otherwise agreed, the Developer shall ensure that all services and drains are laid under carriageways and footways, or ducts provided for them before the base is

laid.

All trenches within the existing highway should be reinstated in accordance with the NRSWA Specification for the Reinstatement of Openings in the Highway. If trenches are within new highway constructed as part of a Section 38/278 Agreement, then the depth of construction and type of material should adhere to the original designed specification.

1.18 Post Construction

When the Developer is confident that all works have been completed in accordance with the approved drawings they should apply in writing to the Project Engineer requesting the issue of a Completion Certificate (S106/278 Agreement) or Part 1/2 Certificate (S38 Agreement) stating that all works have been completed.

For S278 schemes on the existing public highway routine maintenance such as winter service, weed spraying, grass cutting, vandalism and repairs as the result of road traffic accidents will be undertaken upon issue of the Completion Certificate

Part 1 Certificate (for 38 works only)

On receipt of a request from the Developer for the issue of a Part 1 Certificate, the Project Engineer will arrange for a part 1 inspection. This can be issued when all highway drainage (and all other drainage contained within the highway), all kerbing with foundations, carriageway sub base, carriageway base course and vehicle visibility sight lines are completed and to the approval of the inspector. Upon issue of the certificate, the Project Engineer will arrange for the works deposit to be reduced by 50%.

Completion Certificate (Part 2 certificate for 38 works)

On receipt of a request from the Developer for the issue of a Completion Certificate the Project Engineer will arrange for a Stage 3 Road Safety Audit (if applicable) and completion inspection.

When all matters raised in the Road Safety Audit and completion inspection have been addressed by the Developer to the satisfaction of the Project Engineer a Completion/Part 2 Certificate will be issued subject to the following being satisfactorily complete:

- A street lighting inspection (if applicable).
- A street lighting manual (if applicable).

- A structural inspection (if applicable).
 - A structural maintenance manual (if applicable).
 - Confirmation received from the Term Traffic Signals Consultant that any signal installation is acceptable.
 - All agreed Traffic Regulation Orders are operational.
 - **One** set of 'As Built' drawings have been received electronically (in **both** AutoCAD "dwg" format and "pdf" format). **Note: AutoCAD files to be in real world co-ordinates**
 - For a Section 278 Agreement a plan is required showing edged in red the land dedicated as public highway and **all drains to be adopted by the Highway Authority**.
 - For a Section 38 Agreement the adoptable highway should be coloured pink with any highway drainage coloured blue, any adopted sewers coloured black, and any landscaped areas coloured green. Easements should be shown on the pink plan in yellow.
- Note:** If the Highway Boundary has been altered in any way then this also needs to be shown*
- A Health and Safety file (unless exempt by virtue of Regulation 3 of the CDM Regulations). A copy of the approved Health and Safety File should also be provided electronically.

Upon issue of the certificate, the Project Engineer will arrange for the works deposit to be reduced by 90% for 278 works and a further 40% for 38 works. If all the expected works are not complete or there are concerns on any aspects of the works, then a higher percentage of the highway works deposit may be retained.

Maintenance/Final Certificate (for 278 and 38 works)

Following the issue of the Completion Certificate or Part 2 Certificate, a maintenance period (normally of twelve months duration) will commence. During this period the Developer is responsible for the repair of defects and amendments to the design that the Project Engineer considers to be necessary.

At the end of the maintenance period the Developer should apply in writing

to the Project Engineer to request the issue of the Final Certificate. If this does not occur, the Highway Authority will contact the Developer to pursue remedial measures prior to the issue of the certificate.

On receipt of a request from the Developer for the issue of a Maintenance Certificate (S278)/Final Certificate (S38) the Project Engineer will arrange for an end of maintenance inspection and a Stage 4 Road Safety Audit (if applicable).

When all the matters raised in the Road Safety Audit and/or maintenance inspection have been addressed by the Developer to the satisfaction of the Project Engineer a Maintenance Certificate will be issued.

A Maintenance (S278)/Final Certificate (S38) will not be issued until the following have been satisfactorily completed:

- Maintenance inspection
- Stage 4 Road Safety Audit (if applicable)
- Street Lighting inspection (if applicable)
- Traffic Signals inspection (if applicable)
- Structural Inspection (if applicable)

Upon issue of the certificate, the Project Engineer will arrange for the works deposit to be released in its entirety.

SECTION 2 – Design Standards

2.1 Introduction

Further guidance on the design of adoptable roads suitable for adoption are contained in the current version of 'The Essex Design Guide' available from www.essex.gov.uk

2.2 Adoptable Roads (Excludes Industrial Estate Roads – See Clause 2.9)

See Appendix A for information and Tables that illustrate the road hierarchy together with maximum number of dwellings that can be served, minimum carriageway/footway requirements design speeds, visibility criteria and construction types.

2.3 Footways and Cycle Tracks

As part of any new development, Developers shall identify key pedestrian and cycling routes and destinations. Local Transport Note Policy LTN 1/20 Cycle Infrastructure Design produced by DfT, sets out the policy context that supports the promotion of cycling facilities. It also describes common design principles for cycle provision.

Requirements for disabled needs shall be met accordingly. Tactile paving is only expected to be used on road types A – D.

Cycle Track Design Requirements Visibility

Normal design speed – 30 kilometres per hour (20 miles ph.) Minimum Visibility – 30 metres

Minimum design speed – 10 kilometres per hour (6 miles ph.) Minimum Visibility – 10 metres

Radius of Curvature

Normal design speed – 30 kilometres per hour (20 miles ph.) Preferred minimum radii – 25 metres

Minimum design speed – 10 kilometres per hour (6 miles ph.) Preferred

minimum radii – 4 metres

Gradients

Length unrestricted - 3% (1/33) maximum

Up to 100 metres - 5% (1/20) maximum

Up to 30 metres - 7% (1/14) maximum

Gradients above 7% are not recommended except for very short lengths.

Gradients within 10m of any junction or crossing shall be no more than 2.5% (1/40).

Crossfall

Crossfalls of 2.5% (1/40) are desirable generally but may be more, for instance, when super-elevation is required at tight bends. Widening on tight bends should be considered.

Traffic Calming

The Developer shall consider measures that allow the safe and smooth passage for cyclists through any traffic calming measures.

Surface Finish

A smooth non-skid surface course is essential. On carriageways particular attention should be paid to the condition of the surface adjacent to the kerb which is where cyclists usually ride.

2.4 Structures

All publicly owned and maintained highway structures within Essex are referred to as a County Structure.

A structure is defined as being over, under, or adjacent to a highway and:

- Is a bridge (other than a footbridge), culvert, or tunnel that has a span greater than 1.2 metres.
- Is a footbridge with span greater than 8 metres on a public right of way.

- Is a retaining wall, or headwall, with a retained height from finished ground level in front of the wall of over 1.5 metres within 3.66 meters (12 feet) of the highway maintainable at public expense
- Is a noise attenuation barrier exceeding 1.8 metres high (standard ECC/DfT barriers would not require Technical Approval).
- Is a high mast for lightning, lighting systems and/or television cameras.
- Is a sign/signal gantry.
- Is a canopy or building overhanging the highway.
- Is a basement beneath or adjacent to the highway.
- Is designated by the County Council to be a highway structure because of its particular construction, and status.
- Is a modification or addition to an existing structure as defined above.
- Is a buried, water attenuation structure within or adjacent to the highway that has a span greater than 1.2 metres.

All proposed structures require technical approval of the drawings and specifications (Approval in Principle) before any works can commence on site.

The processes for the adoption of a new County Structure are rigorous, lengthy and require specific expertise - *refer to the Essex County Council Technical Approval of Third Party Structures – Guidance Note for Applicants*. This document can be viewed on

<https://www.essexhighways.org/uploads/downloads/development-management/infopack-eurocode-v14-december-2021.pdf>

Structural Inspection Process

With reference to your proposed development Ringway Jacobs would like to draw your attention to our required structural inspection / monitoring process.

Construction should not commence until the design approval procedures have been completed and technical approval issued in accordance with ECC Technical Approval of Third Party Structures:

<https://www.essexhighways.org/uploads/downloads/development-management/infopack-eurocode-v14-december-2021.pdf>

Where a Development Management project includes an adoptable structure,

the Structures Team will attend a pre-commencement meeting with the Clerk of Works and Contractor to agree a schedule of inspections and hold points during the project. Inspection/hold points will be required by the Council's Structure's team at various stages during construction and this will depend on the complexity of the structure.

The first inspection will be at finished excavation for foundations before any blinding concrete or piling work takes place.

Failure to comply with the agreed schedule of inspections and hold points will result in retrospective excavation and testing to determine compliance with the agreed specification and potential rejection of the structure.

The Structures team will require 3 days' notice before the start of any structural work and subsequent inspections / monitoring will require 24 hours' notice. Notice can be given by phone or email to the relevant structure engineer and to the email address structure.enquiries@essexhighways.org

Listed below are the inspections and testing requirements;

Inspection / monitoring –

- Piling operations
- Inspection of formation for foundation
- In-situ structural concrete –
 - Fixing of reinforcement
 - Formwork
- Placement and compaction of structural fill
- Water proofing to concrete structures
- Installation of vehicle restraint system
- Structural steelwork fabrication / installation
- Protective system to structural steelwork
- Road construction over bridge

Testing –

Delivery tickets will be checked, and sample testing will be carried out and certificates will be supplied upon completion for the following;

- Piling operations
- Inspection of formation for foundation
- In-situ structural concrete –
 - Fixing of reinforcement

- Formwork
- Placement and compaction of structural fill
- Water proofing to concrete structures
- Installation of vehicle restraint system
- Structural steelwork fabrication / installation
- Protective system to structural steelwork
- Road construction over bridge

Construction compliance certificate and all information required for record purposes shall be issued in accordance with the ECC Technical Approval of Third Party Structures prior to issue of a Completion Certificate pursuant to any Section 38 or Section 278 Agreement.

Furthermore, a Section 177 licence will be required where any structure overhangs the highway. The legal costs associated with this process are required to be met by the Developer – See Section 1.9 Other Agreements

2.5 Surface Water Drainage

ECC has a policy of not adopting Sustainable Drainage Systems SuDS unless exceptional circumstances prevail. The developer must be able to demonstrate that is not possible for the SuDS to be adopted by a water company, with design changes if necessary.

Any Sustainable Drainage Systems must be designed to effectively reduce surface water run-off and mimic the natural flow path the rainwater takes to the outfall. These systems should be designed to ensure that occupants and properties are protected from flooding and wherever possible that there are reductions in off-site flood risk.

Essex County Council has produced a SuDS Design and Adoption Guide which provides further design information. However, this document was produced prior to the government's announcement that they will not implement schedule 3 of the Flood and Water Management Act 2010 and therefore does not reflect ECC's current position on adoption.

No SuDS feature should lie within the highway boundary under a Section 38 agreement. Any feature that is located outside of the Highway will remain the responsibility of the developer to maintain, offered to the Water Authority or a private management company. There may be other management arrangements that could be considered.

General

The designer of the drainage system for a development shall at the early stages of the design, consider sustainable drainage systems (SuDS). The use of infiltration features will only be permitted after satisfactory results from permeability tests and have been supplied approved by the Project Engineer.

Designers should aim to ensure that surface water from all elements of the development (i.e. housing, roads, footways and private areas) drain to the proposed surface water drainage system and therefore avoid any potential duplication of drainage

systems. Where surface water pipes are laid to drain proposed highways alone, they shall remain highway drains and shall be part of the highway to be adopted. Surface water pipes which accept water from private areas, roofs etc as well as the highway will not be adopted as highway drains. Road gullies and gully connections will always be adopted by the Highway Authority as part of the road.

No part of any highway drain, manhole, gully, etc, must be positioned closer than 3 metres from any structure without the prior approval of the Highway Authority.

Highway Drains

A highway drain must connect direct to a publicly maintained system, that is to a public surface water sewer or watercourse adopted and maintained (or to be adopted and maintained) by the Water Authority, Environment Agency or Essex County Council. The appropriate Authority should be consulted for advice regarding discharges to watercourses or ditches.

The approval for hydraulic, water quality and constructional designs for these surface water sewers, watercourses and outfalls etc. must be obtained from the appropriate authority.

Where the highway drain discharges into an existing ditch or watercourse, the pipe invert (bottom of the inside of the pipe) must not be lower than the level of the average flow in the ditch or watercourse and it should always be

at least 150mm above the ditch or watercourse invert. You must direct the end of the pipe, so it discharges at an angle less than 60 degrees to the direction of flow in the ditch or watercourse. The end of the pipe must have a headwall and apron which supports the bank above and adjacent to the pipe and prevents any scouring underneath the pipe. You must protect the banks of the ditch or watercourse from scouring.

Where an existing highway drain has sufficient capacity, the Highway Authority may be willing to accept a connection of a new highway drain from the development. Permission for such connections should be sought from the Highway Authority. The Developer must provide calculations of the new discharge and will also be required at his own expense, to investigate the condition, current discharge and spare capacity of the existing highway drainage system.

Run off calculations and hydraulic designs will be required for any new length of storm drain that is located within the public highway. The reason for this is because the residents will be likely hold responsible the Highway Authority first if the adoptable road floods the neighbouring properties.

Design factors:

Highway impermeability	100%
Time of Entry	4 minutes
K roughness value	0.6
Minimum flow velocity	1 m/s
Maximum flow velocity	Approval of the Project Engineer
Design storm frequency	1 in 2 years with no surcharging
Minimum pipe size	225 mm
Gully tails	Maximum 10m long
Highway Chambers	Catchpits with 300mm sump To be provided at: <ul style="list-style-type: none"> • Heads of runs • Change of alignment • Junctions • Pipe size Maximum 100m apart
No flooding	1 in 30 years

System check	1 in 100 years (plus 40% climate change)
--------------	--

Climate change shall be accounted for through the precautionary principles recommended in the National Planning Policy framework.

Highway drains should be situated within the limits of the highway wherever possible but outside the carriageway

Where any part of a highway drain, gully connection, soakaway, etc is situated outside of these limits, a formal Deed of Easement will be required to allow the Highway Authority to gain access to the land for maintenance, repairs etc.

Private Drains

Private drains and other private apparatus that lay beneath the publicly maintained highway shall be indicated on the project engineering drawings. Some existing apparatus does not get recorded and will only be discovered during site excavations.

If this is the situation then the Developer must inform the Project Engineer at the earliest opportunity to avoid any delays. A NRSWA Section 50 Agreement (S50 licence) will then be required and must be applied for by the Developer, owner or occupier of the land for them to sign. The person granted the licence will become the undertaker of the apparatus and therefore have relevant duties and responsibilities imposed on them by the NRSWA Act (1991).

Storage

Holding tanks, lagoons, retention ponds, swales etc, together with hydraulic braking systems, may be required for the surface water discharge from a development. The design for such an arrangement will be agreed with the relevant Authority for their adoption.

Holding tanks should be positioned clear of the highway. In certain circumstances, by agreement with the Project Engineer, storage tanks,

pipes etc, may be accepted under the road where their structural integrity must be underwritten by a Structural Design Certificate. No part of such storage tanks, apart from any access shafts etc, must be situated within the road construction layers.

Occasionally storage tanks and hydraulic braking systems/ devices will be acceptable for a highway drainage system. The adequacy of such an arrangement must be fully supported by calculations and approved by the Project Engineer.

The hydraulic braking device used should be a vortex flow control device or other such device as approved by the Project Engineer.

Once a feature listed above is installed on site an agreed means of protection for it during the remaining construction period must be agreed with the Project Engineer.

Some of these features will attract a commuted sum – Please speak with Development Management Engineer regarding cost.

Gullies

The maximum area of carriageway and footway draining to a gully shall not exceed 200 square metres or in the case of shared surface streets 150 square metres.

At vertical curve low point, a gully should be provided together with two separate additional gullies 6.0m either side of the low point or a double cover gully with a single 150mm diameter connection. A double cover with a chute gully arrangement with a single standard connection should also be provided at low spots i.e. low spots which would flood into private property or cause a traffic hazard if water is drained away quick enough.

Additional gullies will be required where there is a likelihood of significant flows of water across open areas of carriageway, e.g. at junctions, transitions of crossfalls etc.

Gully connections must connect direct to a highway drain or other publicly adopted surface water system.

Provision shall be made to deal with surface water from adjoining roads or accesses by the appropriate siting of gullies and drains. Where new estate roads access onto the already adopted highway the locations of the existing gullies, in the vicinity of the new junction, must be clearly plotted on the estate road layout plan. Where relocation of any gullies is required in an existing road, the details shall be agreed with the Project Engineer.

Provision shall be made to prevent surface water from private drives and forecourts discharging onto the present or proposed public highway and similarly to prevent highway water from discharging onto private property.

Soakaways and other Infiltration Features

The Developer will be expected to demonstrate to the Highway Authority that soakaways are acceptable to the Environment Agency and if so whether an interceptor is required. Soakage tests will be required in the location of each of the proposed features.

Seasonal groundwater records may also be required to confirm that the invert of any feature always remain wholly 1 metre above the groundwater table.

The depth of the soakaway from finished ground level shall be determined by the nature of the subsoil.

The location of any feature shall be a minimum of 6 metres from the adoptable highway and a minimum of 5 metres from any building and designed in accordance with the Building Research Establishment BRE Digest 365 (Soakaway design latest revision)

This type of feature will attract a commuted sum – Please speak with Development Management Manager regarding cost.

Petrol Interceptors

In certain circumstances highway drainage systems may require the use of petrol interceptors. These should only be provided following consultation with the statutory water authority and the Environment Agency and with the approval of the Project Engineer.

This type of feature will attract a commuted sum – Please speak with Development Management Engineer regarding cost.

2.6 Street Lighting

Street lighting shall be designed in accordance with the Street Lighting Development Management Specification which is available on the website <https://www.essexhighways.org/adoptions-and-land#docs>

The Developer shall supply to the Project Engineer for approval, the locations of street lighting units and all relevant lighting calculations as detailed in Section 5 of the Street Lighting Development Management Specification prior to commencement of the works.

Lighting shall be planned as an integral part of an estate layout.

Due consideration shall be given to such matters as shared surface roads, proximity of windows, junctions onto existing roads, shared driveways, footpaths, bus stops, amenity areas, parking areas, landscaping and trees including subsequent growth.

As a general rule, road and footpath lighting to be adopted and publicly maintained by the County Council as Highway Authority will be provided in accordance with ECC policy. However, in the case of development in rural parishes where the parish council are the lighting authority, either the lowest category of lighting to British Standards may apply, or lighting may be omitted, either case the scheme shall be approved by the Highway Authority and consultations shall take place at an early stage of the design.

Prospective tenants shall be made aware of the location of lighting columns. The Developer shall include the approved locations on plans used for house sale purposes and install them before house occupation commences.

It should be noted that no land that is to be used to site a lamp column is to be conveyed to adjacent homeowners before the Part 2 Certificate of a S38 Agreement is issued.

2.7 Passively Safe Signposts, Lighting Columns and Traffic

Signal Poles

Passively safe signposts, lighting columns and traffic signal poles shall conform to the requirements of BS EN12767:2007 and TD89/08, Volume 8, Section 2, MCHW.

Passively safe supports shall be provided on all County and Local Network routes unless there is protection provided by a safety barrier.

At locations where safety barriers are not cost effective or appropriate e.g.

- Conflict with underground utilities apparatus.
- Roundabouts where space is limited.
- Nosing or splitter islands where safety barrier end ramps may be a hazard.
- Safety barriers may be visually intrusive.
- Safety barriers difficult to install.
- Speed limits are high.
- Street furniture where location of apparatus poses an increased risk of collision.

Then the following rules should apply to determine if passively safe supports are required:

- The speed limit is 80kph (50mph) or above on an A or B classified road and the sign would require at least one 89mm diameter post and greater than 3.2mm wall thickness as 89mm posts of greater wall thickness are a danger.
- The sign is part of accident remedial measures that have a history of street furniture collision accidents e.g. chevron signs at bends, chevron signs at roundabouts, repeated sign knock downs.

Guidance on the requirements for passively safe posts, columns and poles can be obtained from the Safety Engineer – contact via your Project Engineer.

2.8 Car and Cycle Parking

Parking provision for new adoptable roads should be designed in accordance with Parking Standards Design and Good Practice 2024

available on [2024 Essex Parking Guidance | Essex Design Guide](#)

2.9 Industrial Estate Roads

Although the general principles and advice given in the 'Essex Design Guide' and elsewhere in this manual apply equally to industrial estates, the layout of these roads has a different emphasis from that of residential roads.

In order to cater for the larger and heavier vehicles the roads need to be of greater width and strength.

The necessary changes to the design standards to cater for this traffic are set out in this section.

General

Industrial estate roads have been categorised as follows:

- i. Major Industrial Roads
- ii. Minor Industrial Roads

In general, only cul-de-sacs of less than 200 metres in length shall be considered as Minor Industrial Roads with all others being Major Industrial Roads. It is not necessary to use both categories in a development.

Details of design are summarised in Appendix A Table 1. These should be read in conjunction with Section 4 of this manual and the following notes;

- i. Forward visibility is measured on the centre line of the carriageway
- ii. On Major Industrial Roads where the gradient is greater than 6% (1 in 16.7) an increased carriageway width may be required.
- iii. Footways must be provided on both sides of the carriageway; the width of 2 metres may need to be increased in certain cases to cater for heavier pedestrian flows and shared cycle use.
- iv. Increased carriageway width may also be required on sharp bends to enable larger vehicles to pass each other (see Appendix A Table 2).

Cul-de-sacs over 200 metres in length are undesirable but will be considered in certain circumstances up to a maximum of 400 metres in length beyond which a second access to the existing highway network should be provided.

Where the 200 metres maximum length is exceeded intermediate turning facilities must be provided at a maximum spacing of 200 metres.

Where an Industrial Estate Road joins an existing Local Distributor Road, offside diverging (right turn) lanes may be required to be provided by the Developer, together with associated traffic signs, central refuges and road markings. Under normal circumstances offside diverging lanes will be required at all junctions between Distributor Roads and Major Industrial Roads. Details of pedestrian facilities may also be required to be agreed with the Project Engineer. The use of roundabouts and mini-roundabout junctions will be considered where appropriate.

Visibility

Where a new estate road joins the existing wider highway network, or within an industrial estate visibility will be required to be in accordance with TD41/95 and TD42/95 and any succeeding technical directives.

Visibility on curves, at summits and at junctions shall be provided between points 1.05 metres above the carriageway.

Turning Spaces

A turning space shall be provided at the end of each cul-de-sac. This turning space must be in accordance with one of the diagrams shown in Appendix B Figure 4.

The positioning of accesses to individual premises within turning spaces is recommended as this discourages casual parking which obstructs turning movements.

Gradients

The gradients used shall normally not exceed the following limits:

- Maximum gradient 6.00% (1 in 16.7)
- Minimum gradient 0.80% (1 in 125)

In exceptional circumstances flatter gradients will be permitted where it can be demonstrated that the road will drain adequately allowing for normal surface course tolerances.

Where the channel is formed of precast concrete or where other suitable channel drainage kerbs are used, the gradient shall not be less than 0.67% (1 in 150).

Construction Design

Carriageway construction thickness shall be in accordance with Appendix A Table 3 and footway construction shall be in accordance with Appendix A Table 5.

Access

The layout of premises shall be such that all vehicles can leave and re-join the public highway in a forward direction.

For access to premises, radius kerbs (not less than 6.0 metres) should be provided. The width of accesses to premises will depend on the size and the nature of the

premises and should be determined at the planning stage. In addition, an area of footway 2 metres long on each side of the access shall be constructed to carriageway standards to reduce the effects of vehicles mounting the kerb.

Parking

All necessary provision for vehicle parking including deliveries should be clear of the public highway. In general, parking to serve premises is not acceptable on the highway and the Developer will be expected to meet the full costs of Traffic Regulation Orders (TRO's), signs and road markings required to enable waiting restrictions to be implemented where appropriate.

2.10 Public Transport (see also Appendix F – Passenger Transport Infrastructure Standards Guide – Abridged Version)

Streets likely to be used by Public Transport should be identified in the design process working in partnership with The Public Transport Operators and Highway Authority to ensure integration of local services into the wider network strategy

Early reference should be made to the Passenger Transport Team of Essex County Council. This team can provide a copy of the Passenger Transport Infrastructure Guidance where it particularly applies to Developers.

The locations of bus stops/shelters should be indicated and agreed early on in the design process to ensure that any potential buyer is aware of where they are located.

If any existing bus stop needs to be temporarily suspended due to proposed highway works information on the process is provided in Appendix F of this document.

2.11 Traffic Regulation Orders (TRO)

Some functions on the Highway need restrictions to ensure safety, accessibility and minimum disruption to local life.

Parking restrictions may be necessary in certain locations such as at road junctions, town centre developments or areas where commuter/school parking may be an issue. This will require a Traffic Regulation Order (TRO).

Prospective property purchasers should be made aware of any potential TRO's at an early stage.

As well as parking restrictions, other TRO's may be required including:

- Speed zones/limits
- One-way orders
- Weight, height and width restrictions
- Certain road humps on the public highway
- No entry

All pedestrian crossings also require formal advertising before works can commence. The procedure for these differs from other TRO's as the public only have a right to comment not object.

TRO's will be arranged by the County Council with the associated costs met by

the Developer (See Clause 1.10 Payment of Costs). The Developer shall liaise with the Project Engineer to ensure timely delivery of the orders.

TRO's involve a statutory process where the outcome is not guaranteed due to the public's right to object. It is advised that any sensitive TRO is processed before planning permission is granted to ensure that the planning permission can be delivered.

All TRO's processed will be subject to a maximum two-year period from the date of formal advertising of the restrictions in which the Developer must ensure the TRO becomes operational. It is strongly advised that developers use this window to process applications before the houses are occupied. All TRO's should be shown on all drawings.

2.12 Public Rights Of Way (PROW)

The design, specification and construction required for the PROW will be determined by the rating of the route in the network hierarchy.

The Developer shall ensure that any PROW shown on the Definitive Map and Statement are given due consideration in line with the following: -

- Make provision for existing PROW which will be affected by the Development.
- Make provision for any claimed or proposed PROW.
- Apply in good time (allow 9 months, although turnaround times differ in each Local Planning Authority responsible for processing the diversion) for diversion orders under the Town and Country Planning Act 1990 for any PROW which are affected by the Development.
- The processing of these orders will incur a fee, but this may differ according to the district in Essex and therefore should be clarified with the Local Planning Authority.

If the PROW is not diverted under the above process and becomes obstructed, then this causes significant legal problems as the Highways Act 1980 has to be used and can potentially lead to a negative outcome. The timescale for this process is 18 months due to the involvement of the Magistrates Court.

Further information regarding PROW may be obtained from the Essex County Council website or the Definitive Map Service department.

SECTION 3 – General Requirements

3.1 Existing Street Furniture and Fittings

At the discretion of the Project Engineer, any highway furniture or equipment arising from an existing road made surplus as a result of the works shall be delivered to a place within Essex of our choosing at the Developer's expense.

3.2 Protection of the Public

The Developer shall guard, fence, light and maintain all obstructions within or adjacent to an existing highway resulting from or in connection with the site works in accordance with the current requirements of Chapter 8 of the Traffic Signs Manual – Traffic Safety Measures for Roadwork's (DfT) and Safety at Street Works and Roadworks – A Code of Practice (DfT)

3.3 Protection of Existing Structures, Walls, Fences etc

For all works within or adjacent to the public highway the Developer shall, during the progress of the works, make arrangements for the safety, protection and stability of all structures, walls, fences, hedges, trees, land drains, sewers and apparatus, and they shall also be responsible for rectifying or repairing at their own expense, any damage to private or public property that may have been caused by their operations.

It shall be the responsibility of the Developer to satisfy themselves as to the accuracy of any information which may be made available by the Highway/Drainage Authorities and Statutory Undertakers.

3.4 Protection of Water Courses

The Developer shall be responsible for keeping existing watercourses clear and unrestricted where such operations interfere or have interfered with them in any way and shall be held responsible for any flooding and damage caused by their failure to carry out these requirements. The Developer shall take all necessary precautions to prevent tar, oil, bitumen, cement or other polluting substance entering any watercourse or surface water sewer.

3.5 Protection of Existing Trees and Landscaping

The Developer shall take appropriate measures to ensure that all trees, hedgerows etc. required for retention are not to be removed or damaged by the works (refer to section 4.14 - the Highway Authority `No Dig Policy`)

Where tree surgery is required, the services of a competent tree surgeon should be used using British Standard 3998:2010 as a minimum standard.

Existing trees and associated landscape works within or adjacent to the existing highway shall be discussed with the Highway Authority at all stages of the works.

The Developer's attention is drawn to document BS5837:2012- Trees in Relation to Design, Demolition and Construction – Recommendations and NJUG Volume 4 - Guidelines for the Planning, Installation and Maintenance of Utility Apparatus in Proximity to Trees.

Further information can be obtained from the tree officer (Arboculturalist) at ECC. For further details including plant species. Refer to the Essex Design Guide <https://www.essexdesignguide.co.uk>

3.6 Control of Noise

The Developer shall comply with the general recommendations set out in BS 5228-1:2009 and BS 5228-2 :2009 – “A Code of Practice for Noise and Vibration Control on Construction and Open Sites” when working within or adjacent to the public highway. Developers shall seek advice from the local District/Borough Council's Environmental Health Department.

3.7 Working Adjacent to Existing Highways

The Developer shall at all times take such precautions and adopt such measures as are considered necessary by the Project Engineer to ensure the safety and convenience of the public and owners/ occupiers of affected property. Interference with the use of the highway access to private property should also be minimised. The safe passage of vehicles and pedestrians shall at all times be maintained throughout the construction period unless the highway is closed with the agreement of the Project Engineer and by due statutory process.

No work within the existing highway shall take place without the written consent of the Project Engineer and the entering into of the appropriate agreement and issuing of a Works Licence or Permit to Work. A Road Opening Notice that complies with the NRSWA Act 1991 is also required (refer to Clause 3.8 below).

3.8 Openings in Publicly Maintainable Highways

The Developer shall obtain from the relevant County Council Street Works Co-ordinator the appropriate 'Road Opening Notice' in respect of openings in publicly maintainable highways and shall comply with the New Roads and Street Works Act 1991 (NRSWA).

3.9 New Roads and Street Works Act 1991 (NRSWA)

Under the terms of the Act the Developer shall contact the Street Works Co-ordinator for the area where the proposed works are to take place and agree the timing of their works (refer to section 1.16)

3.10 Construction (Design and Management) Regulations 2015 (CDM)

The Developer shall work in accordance with the Construction (Design and Management) Regulations 2015 at all times. A Health and Safety file must be instigated in accordance with the CDM Regulations 2015.

This is a record of information for the client/end user, which tells those who will be responsible for the development in future of the risks that have to be managed during maintenance, repair, renovation or demolition. This file shall be updated as the development progresses and given to the Highway Authority upon completion of the works. The Developer acting as "Client" shall also confirm whether the development is "notifiable" and, if it is, produce written proof that the Health & Safety Executive have been informed.

The Principal Designer shall ensure that a Health & Safety File is prepared and ensure co-operation between all parties involved in the project.

Where design input is made by the Highway Authority, it is the responsibility of the Developer acting as Client and their Principal Designer to develop and

assess the implications of the design input under the CDM Regulations.

3.11 Road Safety Audits

Road Safety Audits may be required by the Project Engineer and if deemed necessary will be carried out as follows:

- Formal Stage 1 Safety Audit – undertaken on completion of outline design and submitted by the Developer with the planning application unless otherwise agreed by the Project Engineer
- Formal Stage 2 Safety Audit – on completion of detailed design but prior to technical approval.

Note: *If the design changes significantly a further Stage 2 Safety Audit will be required.*

- Formal Stage 3 Safety Audit – towards scheme completion prior to issue of completion certificate
- Formal Stage 4 Safety Audit – from scheme becoming operational and before the Maintenance/Final Certificate expires (usually 12 months) and only at the discretion of the Project Engineer

Any issues arising from the safety audit reports are to be dealt with and paid for by the Developer. Stage 2- 4 safety audits are ordered by the Project Engineer and funded through inspection fees, with the exception of Minor Works Authorisations where additional fees will be required to cover Road Safety Audits/Assessments.

Note: *Auditors shall be independent from the design team and ROSPA trained. A draft report shall be sent to the Project Engineer. The Designer/Project Engineer is required to respond for the report to be final. The report shall be signed off as final within 3 weeks after draft submitted. See DMRB Vol5 section2 HD 19/03.*

3.12 Preliminary Site Meeting and Inspections

At least two weeks prior to the commencement of site works, the Developer shall convene a site meeting with the Project Engineer and nominated Clerk of Works to discuss the works programme and the effect of the development

on existing highways and statutory undertaker's apparatus.

Prior to works commencing on site the Developer should give the Project Engineer/Clerk of Works three days' notice and in the case of the construction of foul or surface water sewers intended for adoption by the Water Authority located under proposed public highway, appropriate notice shall also be given to that authority.

Notice for required inspections once works have started shall be at least 24 hours and should be given to the relevant Clerk of Works.

All reasonable facilities shall be given to the Project Engineer/Clerk of Works for the inspection of the various elements of the works whilst in progress, including highway drainage.

Inspections required by ECC are:

- 1) Drainage inspection. (Backfill, Laterals, Gullies)
- 2) Inspection of formation, (witness proof rolling)
- 3) Approve capping layer, (CBR dependent)
- 4) Sub-base inspection
- 5) Kerb line inspection
- 6) Base Course inspection
- 7) Binder Course inspection
- 8) Surface Course inspection
- 9) Inspection of street light positions prior to installation

***Note:** Other inspections may be deemed necessary by the Project Engineer due to the specific nature of the works being undertaken e.g. embankment stability/protection measures.*

3.13 Commencement and Programme of Works

No work shall commence until the working drawings, specifications, structural and drainage calculations have been submitted to and given technical approval in writing by the Project Engineer.

Furthermore, no works within the public highway shall be commenced until written confirmation of any diversionary works in respect of undertakers' apparatus has been supplied and/or details of any works related thereto have been approved by the undertaker concerned.

The Developer shall provide the Project Engineer with a programme of works prior to commencement on site.

The programme shall include an outline of the order and method of working including temporary traffic management together with an indication of materials, suppliers and sub- contractors. If the works, having been started, are discontinued for a period longer than 14 days, three days' notice shall be given to the Project Engineer before work is recommenced.

3.14 Project Engineering Drawings

All works shall be executed in accordance with the approved drawings, specification and other required details and no alterations shall be made without prior approval of the Project Engineer.

All site investigations and other relevant information must be made available to the Project Engineer at the design stages e.g. California Bearing Ratio (CBR), frost susceptibility results and material types within trial holes and boreholes. CBR test results of less than 2.5% will require special consideration with respect to the specification for construction Appendix A Table 5.

3.15 Setting Out

The line and level of the formation, side slopes, drains, carriageways and footways, etc. shall be carefully set out in accordance with the planning consent, to an approved method and frequently checked by the Developer to ensure that the gradients and cross sections are in accordance with this manual and the approved drawings.

The Developer shall provide for the use of the Project Engineer all instruments and/or equipment and labour to assist them with any levelling, measuring, checking or inspection as deemed necessary. The checking of any setting out of line or level by the Project Engineer shall not in any way relieve the Developer of his responsibility for the correctness thereof.

3.16 Cold Weather Working

No material in a frozen condition shall be incorporated in the works and

material for use in road pavements shall not be laid on any surface which is covered with ice or snow.

Laying of bituminous materials in adverse conditions shall be in accordance with BS EN13108:2006 and PD6691:2010 – Guidance on the use of Bituminous Mixtures.

The laying of pavement materials containing cement shall cease when descending air temperature in the shade falls below 3°C and shall not be resumed until the ascending air temperature in the shade reaches 3°C. Proper protection from frost shall be afforded to all newly laid cement bound materials.

Additionally, the temperature of the fresh concrete at the time of delivery into the construction shall not be less than 5°C.

3.17 Construction Levels

During all phases of construction, it is important that the Developer ensures that the works are constructed in such a manner that they are not liable to damage during the remainder of the works and that they do not constitute a hazard. In particular, attention should be paid to carriageway construction layer levels in relation to manhole/gully covers.

3.18 Routing of Construction Vehicles

Before the commencement of the works, the Developer shall provide the Project Engineer details of all routes and the location and details of temporary road signs to be used for construction vehicles gaining access to the site. In some cases, the route(s) will be controlled by a planning condition.

If the development involves adoptable works, the routes and signage shall be agreed by the Project Engineer prior to commencement of work and the routes or any agreed variation shall be inspected by the Developer and Project Engineer to establish the existing condition of the roads prior to use by the construction traffic.

The Developer will be required to remedy any damage caused or increased

by construction traffic.

3.19 Keeping Highways Clean

It is an offence under the Highways Act 1980 to deposit mud etc on a public highway. Prior to commencement of the works, the Developer shall, where required by a planning condition/the Project Engineer, provide within their site boundaries, vehicle and wheel cleaning apparatus to ensure that public highways affected by the site are kept clean. The Developer shall ensure that the facility is maintained in good and useable condition and that it is used by all vehicles before they leave the site.

Any detritus that is deposited on the public highway that has emanated from the Development shall be removed at the earliest opportunity.

3.20 Parking for Site Staff

Prior to the commencement of the works, the Developer shall provide adequate parking facilities within the site boundaries for all site personnel vehicles. The Developer shall ensure that all site personnel use the parking facility and that they do not park on the public highway when attending the site.

3.21 British Standards Specification

British Standards (BS) referred to shall be the most recent edition at the time of the development works.

Wherever, in respect of any BS reference, a scheme of supervision and control is in operation, all materials required to comply with that standard shall be marked with the BSI Certification Trade Mark (the 'kite mark').

This clause shall also apply to any addendum or amendment which may be issued in relation to this specification.

3.22 Testing – General

Before work commences, the Developer shall make all necessary arrangements for the testing of materials used in connection with the carrying out and completion of the works, by an independent UKAS

accredited testing facility, as required by the Project Engineer or their representative, and shall bear the full cost of any such testing and provide the Council with copies of all material testing certificates.

Tests applied to particular materials will be those specified in the appropriate BS covering such materials. Refer to Appendix D for the details of materials testing and frequency of sampling required by ECC.

During the execution of the works, materials for test will be selected from batches or consignments on the site, and any materials which fail to pass the relevant test shall be removed from the site of the works. The Developer shall comply with the frequency of sampling and testing of concrete which is covered in Appendix 1/5, Table 1/1, Series 100, MCHW.

If any part of a defective batch or consignment shall have already been embodied in the works, the section affected shall be removed and replaced by material which complies with the specification.

The Developer shall be required to provide assistance, instruments, labour and materials for other tests identified by the Project Engineer/Clerk of Works and deemed to be necessary and shall be responsible for taking and transporting of all samples at own expense to the laboratory.

3.23 Ground Investigation and Design CBR

The strength of many soils in Essex is very dependent upon moisture content, condition and density, and the soils can exhibit rapid loss of strength as the moisture content increases.

The susceptibility of the subgrade to loss of strength depends on its plasticity index, the position of the ground water table and the anticipated moisture content of the subgrade.

A soil survey shall be carried out at an early stage and must include tests sufficient to establish the Californian Bearing Ratio (CBR) value and frost susceptibility of each sub-soil type encountered – refer to CD225 Design for New Pavement Foundations published by National Highways. The location of the test areas shall be agreed with the Clerk of Works and the subsequent results and interpretation of the soils surveyed made available to the Clerk of Works.

Project engineering drawings submitted for approval must include a ground investigation report incorporating soil classification and in-situ moisture contents, frost susceptibility as well as results of CBR tests in order to determine the bearing capacity of the formation along the line of the proposed road.

As a result, the thickness of any additional sub-base/capping layer material must be agreed with the Project Engineer/Clerk of Works.

3.24 Tests for Structures

The design of a structure (refer to section 2.4) shall require the determination of the appropriate soil parameters in accordance with the relevant British Standard. It is likely that other testing methods shall be required (refer to Appendix D).

3.25 Bulk Density and Air Void Determination of Bituminous Materials

Where it is required to determine of air void content or the Percentage Refusal Density (PRD), 150mm diameter cores shall be drilled in accordance with the relevant part of BS EN 12697. Where access or limited layer thickness prevents the drilling of cores, cut-out samples of area not less than 150 x 150mm shall be taken.

The number and spacing of the cores shall be determined by the Project Engineer but shall be sufficient so as to provide a realistic value for the overall level of compaction for the area under test.

The determination of air voids and PRD shall be in accordance with the relevant part of BS EN 12697. The total air voids for each core shall be derived from the differences between the theoretical mean dry density of the material calculated from the specific gravities of the constituents of the mix and the directly measured density.

3.26 Determination of Layer Thickness and Bond

Where it is required to confirm that the specified layer thickness has been laid or that a bond has developed between layers, 150mm minimum cores shall be drilled vertically through the construction at locations to be agreed by the Project Engineer. Where limited access prevents coring then cut-outs of area not less than 150 x 150mm shall be taken.

Should any doubt exist concerning any requirement of this section the Project Engineer shall be consulted prior to proceeding.

3.27 Minimum Length of Road Construction

A minimum length of 50 metres is recommended for any new length of road construction. Any length less than 50 metres can only be constructed with the agreement of the Inspection Team.

3.28 Carbon Reduction

Carbon Reduction

Essex County Council (ECC) owns a vast network of highway infrastructure assets. Highways therefore has an important role to play in supporting the Council's net zero targets.

Quality Control

Developers and their contractors are expected to employ robust quality control measures to reduce the likelihood of abortive or defective works.

Innovation

Innovative ideas to reduce carbon emissions are welcome. These will be shared with the relevant Essex Highways working group for consideration.

Performance Notice

Developers and their contractors who demonstrate notable efforts to reduce their carbon footprint will be eligible for a performance notice.

Programme/Other Works

A programme of works is required upon receipt of all MWA/S278 applications. Checks will be undertaken to determine whether there are any other planned works in the vicinity which may conflict or otherwise be superseded by the MWA/S278 application. Sometimes collaborative working can be achieved where safe to do so; this should be assessed during the programming stage and if feasible can provide carbon reduction benefits and create less disruption to road users.

Sourcing Materials/Products

Sourcing approved materials/products from local suppliers is encouraged. Minimising the distance for transportation can help reduce carbon emissions.

SECTION 4 - Materials and Workmanship

4.1 Introduction

All materials used upon the works shall comply with this manual.

For general requirements concerning compliance with British Standards refer to section 3.21.

All materials and workmanship shall be the best of their respective kinds and comply with the appropriate British Standard(s), the Code of Practice (where applicable), this manual and be to the Project Engineer's approval. Unless stated to the contrary the thickness of the material described shall mean the finished or compacted thickness.

All materials brought to the site for use in the works shall be deposited and stored so as to secure them from damage and from contact from harmful material until they are required for use. Materials shall not be deposited within the existing public highway or in such a way as to inconvenience and endanger the public or within the spread line of trees to be retained.

The Highway Authority is keen to encourage the use of recycled materials. As such recycled materials will be acceptable subject to assurances being given that the materials can meet the minimum requirements of conventional materials. Current test certificates (provided by a UKAS accredited provider) shall be supplied to the Project Engineer or Clerk of Works with a gradation test a minimum requirement. There may be a need to agree additional inspection and testing (See Appendix D).

If any sheds or storage buildings are erected on the site such buildings shall be sited so as not to obstruct access to any property and the reasonable free passage of pedestrians and/or vehicles. Upon completion of the works the buildings shall be removed from the site and the area left tidy. No buildings shall be positioned within the existing public highway.

4.2 Site Clearing and Earthworks

4.2.1 Order of Earthworks

Where required by the Project Engineer the Developer shall provide details of the method, phasing and timing of any earthworks that are required within the site.

4.2.2 Site Clearance

In carrying out earthworks, the Developer shall take care not to disturb unnecessarily the site or allow materials to be deposited on adjacent highways.

In the case of buildings, all foundations, drains, wells and inspection chambers shall be excavated, taken up and the holes backfilled with approved materials and compacted. Should any of the above elements require excavations deeper than 5m then immediate notification shall be given to the Project Engineer to enable an inspection to take place. In exceptional circumstances a representative from the Environment Agency may also be required to inspect the element of the works e.g. where an underground spring is present. The Developer shall seal drain connections where required and shall give notice to statutory authorities to adjust all gas, water, telecoms and electric as necessary.

The Developer shall carry out the works in such a manner as to cause as little inconvenience as possible to the public and will be wholly responsible for the safety and protection of any other buildings, structures and environment adjacent to the site.

4.2.3 Trees and Hedgerows

No trees or hedgerows are to be removed without consultation with the planning authority. Trees, hedges and stumps where so permitted shall be removed completely including the roots.

The holes resulting from grubbing up shall be filled and made good with approved material and compacted.

4.2.4 Removal of Topsoil

All topsoil shall be removed from embankments and under paved areas.

Any material suitable for re-use shall be stockpiled in a safe manner to the approval of the Project Engineer.

4.2.5 Bulk Excavation and Filling

Excavation and filling shall be carried out in accordance with the approved drawings or as otherwise directed by the Project Engineer.

Where the following materials are present under the proposed adoptable works they shall be excavated and disposed of to a licensed tip by a licensed haulier.

- Peat material from swamps, marshes and bogs
- Logs, stumps and perishable material
- Materials susceptible to spontaneous combustion
- Frozen materials
- Material which by its moisture content is unsuitable to form stable and effective works
- Material having hazardous chemical or physical properties which require special measures for excavation, handling, storing, transportation, deposition and disposal
- Any other material not acceptable to the Project Engineer.

Materials intended for infilling shall be kept separate from other materials and shall be protected from becoming unsuitable by contamination, weathering or by an increase or decrease in the moisture content.

The Developer shall be required to submit details of his proposals for filling the areas in question for written approval by the Project Engineer who may require the appropriate tests.

The material and compaction shall generally comply with the requirements of Table 6/1 of Clause 601, MCHW.

4.2.6 Treatment of Unsound Ground

Where unsuitable material has been exposed beneath, adjacent to or in a location likely to affect the adoptable works, such material shall be excavated.

Any resulting depressions shall be filled with approved materials and in such a manner agreed with the Project Engineer.

4.2.7 Excavations for Carriageways

All topsoil shall be removed from the area to be occupied by the carriageways and footways. The general excavation to the level from which final preparation of the formation is made shall then be carried out and the excavated material removed. Where the material at formation level is unsatisfactory as a foundation for the carriageway or footway pavement, the Developer shall excavate to such extra depth as the inspection may direct. In excavating to formation, the Developer shall take care not to remove material below that level. If material is to be removed the Developer shall make up the required level with approved material.

As far as practicable, the excavation work shall be carried out immediately prior to the laying of any part of the carriageway pavement. If for any reason the sub-grade is disturbed, or its natural moisture content changed so as to reduce the bearing capacity, additional excavation shall be carried out.

Any excavation to within less than 75mm of the formation level shall be considered as exposure of the formation and shall be carried out only so far ahead of the laying of the carriageway or footway pavement as the Project Engineer may agree. No traffic other than that used for the excavation and disposal of spoil shall be permitted on the sub-grade once the surface soil has been stripped. No traffic shall be allowed on the prepared formation. Trimming and shaping shall be carried out by hand, or by mechanical means to the approval of the Project Engineer.

4.2.8 Treatment of Side Slopes

The sloping sides of all cuttings shall be carefully and evenly trimmed and cleared of all rock fragments which move when prised with a crowbar and are therefore liable to cause injury or damage through falling.

Where in the sloping sides of cuttings layers of rock and softer materials alternate, or where the Project Engineer considers that the materials after dressing and exposure will not permanently withstand the effect of weather, such insecure materials shall be excavated to an approved depth and the resulting spaces built up with

concrete so as to ensure a solid face.

4.2.9 Filling Materials - General

All filling materials used within the works shall be to the approval of the Project Engineer. The maximum permissible moisture content for well graded granular material and uniformly graded granular material shall not exceed the optimum moisture content by more than 1.5% as determined from BS 1377 - 4:1990 using the 2.5 kg rammer method or vibrating hammer method as appropriate for the type of the fill material used.

Acceptability criteria for the use of cohesive and chalk materials shall be agreed with the Project Engineer prior to commencement of the works.

4.2.10 Materials for Embankments

All filling material shall be deposited in layers not exceeding 225mm loose depth. Each layer shall extend over the full width of the embankment and shall be compacted. Isolated boulders each within the range of 0.02m³ to 0.09m³ in size may be incorporated at depths more than 600mm below the formation, provided that all specified compaction requirements can be met.

During the construction of embankments construction traffic shall be directed uniformly over the whole width.

4.2.11 Forming of Embankments

Generally, slopes shall be no greater than 1 in 3, to have a French Drain or equivalent at the toe of the slope, to have a minimum of 1m wide level verge at top and bottom of slope. For large areas with grass that will need to be cut, the maximum earthworks gradient should not exceed 1 in 5

Embankment slopes that are over-steep and/or require some form of soil reinforcement (geogrids, soil nailing, etc) will be treated as a structure and will need to be checked by a specialist in earthworks.

All materials used to form an embankment for highway purposes shall be material suitable for the purpose.

Materials of widely divergent characteristics shall be deposited in separate layers.

Chalk or other frost susceptible material will not be permitted within 450mm of the finished surface level of the carriageway or other surface subject to vehicle traffic.

Fill for compaction against structures shall not have a water-soluble sulphate content greater than 1.5g/litre when tested in accordance with the requirements of BS 1377: 1990 Part 3 and shall consist of well graded crushed or uncrushed gravel, stone rock fill, crushed concrete, slag or natural sand or a combination of any of these and shall have a moisture content not exceeding the values given in Clause 8.1.11. Not less than 95% of the material shall pass a 125mm BS Sieve and at least 90% shall pass the 75mm BS Sieve but not more than 5% shall pass the 75-micron BS Sieve.

4.2.12 Maximum Moisture Content

Work on the compaction of excavated materials shall proceed as soon as practicable after excavation so that the moisture content does not exceed the following values:

- Cohesive soils – 1.2 x plastic limit to BS 1377 1990 Part 2.
- Non-cohesive soils – optimum moisture content + 1½% to BS 1377 1990
- Part 4 (2.5kg rammer or vibrating hammer as appropriate)
- Upper and middle chalk – 30% (saturation moisture content not greater than 20%)
- Lower chalk – 18

Chalk shall not be excavated, placed as fill or compacted during the period 31 October to 31 March unless permitted by the Project Engineer.

4.2.13 Embankments Over Culverts

In carrying an embankment up to or over bridges, culverts or pipe drains, care shall be taken to ensure that the embankment is built up progressively and at the same time on both sides of the structure. The quality of the fill material and the degree of compaction shall comply with this specification. An adequate thickness of material as directed by the Project Engineer shall

be placed and compacted over the top of any such structure before heavy construction traffic is allowed to pass over it.

4.2.14 Temporary Drainage of Earthworks

Provision shall be made for the rapid dispersal of water entering or falling on the earthworks from any source at any time during the construction. Such temporary arrangements and works shall be sited as to cause no defects in the completed works and in the case of it becoming necessary to lead water temporarily down a side slope, temporary flumes shall be provided.

The Developer shall not, without the written permission of the Project Engineer, the Environment Agency or Water Authority, as appropriate, pump any water into any stream, sewer or highway drain, and where permission is granted, shall provide means for preventing silt, soil and other deleterious material from entering these conduits.

At all times during the progress of the works the slope and levels of the surface layer shall be such that it is self-draining and special care shall be taken to keep the surface free from ruts, to prevent the accumulation of standing water.

4.2.15 Preparation of Formation

Preparation of the formation shall be carried out only after completion of the subgrade drainage and immediately prior to the laying of the sub-base or base course. All surfaces below carriageways, laybys and footways shall be cleaned and free from mud and slurry. The surface shall then be compacted if necessary, to satisfy the density requirements in BS 1377.

4.2.16 Soft Spots

Any soft or unstable places in the formation shall be excavated and replaced with approved material which shall then be compacted in accordance with the requirements of BS 1377.

4.3 Foul, Surface Water and Subsoil Drainage

Drainage design and construction shall comply in all respects with the latest edition of 'Sewers for Adoption' unless otherwise specified.

4.3.1 Excavation of Trenches

Excavations are to be carried out to the lines, levels and dimensions shown on the approved drawings or to such other levels and dimensions as may be directed by the Project Engineer.

The Developer shall supply all timbering, steel sheeting, steel piling or other approved supports as necessary for securing the sides and formation of all excavations. Any excavation taken out deeper than required shall be filled to the required level with approved material. There shall be a 150mm clearance between the outside of the sockets of the pipes and the sides of the trench or sheeting.

4.3.2 Dealing with Water

The Developer shall, during the progress and execution of the works, keep the trenches and other excavations dry and at all times free from subsoil water and surface water. The Developer shall not, without the written permissions of the Project Engineer and the Environment Agency or Water Authority (as appropriate), pump into any stream, sewer or highway drain.

Where permission is granted, the Developer shall provide means for preventing silt, soil and deleterious material from entering these streams, sewers and drains. The Developer shall keep a SuDs feature clear from contaminated water and ensure that no water heavily laden with silts or other construction detritus enters the feature. Any surface water is to be controlled at source and should form part of the method statements for construction SuDs features.

4.3.3 Concrete Pipes and Specials

Concrete pipes and specials shall comply with the requirements of BS 5911 'Precast Concrete Pipes Fittings and Ancillary Products' Part 100 and BS EN 1916.

4.3.4 Concrete Perforated Pipes

Concrete perforated pipes shall comply with the requirements of BS 5911 'Precast Concrete Pipes Fittings and Ancillary Products' Part 110.

4.3.5 Concrete Porous Pipes

Concrete porous pipes shall comply with the requirements of BS 5911 'Precast Concrete Pipes Fittings and Ancillary Products' Part 114.

4.3.6 Vitrified Clay Pipes Fittings and Ducts

Vitrified clay pipes, fittings and ducts, also flexible mechanical joints for use solely with surface water pipes and fittings shall comply with BS 65:1991. Vitrified clay pipes, fittings and joints for drains shall also comply with BS EN 295 - 1 to 3:1991.

4.3.7 UPVC Pipes

UPVC pipes and fittings shall comply with the requirements of BS EN 1452 – “Joints and fittings for use with unplasticized PVC pressure pipes” (parts 1, 2 & 3).

4.3.8 Iron Pipes

Iron pipes, bends, junctions and fittings shall be provided with spigot and socket joints and shall comply with the requirements of BS EN 598:2007.

4.3.9 Laying and Jointing Pipes with Flexible Joints

Flexible jointed pipes shall be laid in accordance with Clause 503, MCHW on bedding as shown on drawings F1 and F2, Volume 3, Section 1, MCHW.

4.3.10 Mortar

Except where high performance mortar is required, mortar shall consist of Portland cement and sand, both as specified in the following proportions:

For brickwork, jointing slabs etc, 1 volume of Portland cement to 2.5 volumes of sand.

For jointing kerbs, pointing brickwork, pipe jointing etc, 1 volume of Portland cement to 2 volumes of sand.

The sand to be used shall comply with BS EN 13139:2002. Mortar shall be mixed with the minimum amount of water for the purpose required.

The use of a sand/cement mortar for bedding of manhole and gully frames is

not permitted.

The bedding mortar that is used for manhole & gully frames shall be a high-performance bedding mortar that meets the compressive strength and rapid setting requirements below:

- (a) – The material shall be non-shrink
- (b) – Minimum workable life of 15 minutes
- (c) – Exceed 30N/mm. sq compressive strength in 3 hours
- (d) – Exceed 5N/mm. sq tensile strength in 3 hours

4.3.11 Type of Brickwork Bond and Mortar Laying Joints

An English Bond is required to all brickwork supporting covers and frames within the Adoptable Highway unless specified differently. Mortar laying joints should be between 12mm-18mm.

4.3.12 Damage to Joints

Great care shall be taken to ensure that the components of the flexible joints are not damaged in any way during unloading, storage or laying.

4.3.13 Concrete Bed and Haunch

All pipelines with rigid joints, irrespective of depth shall be laid on a 150mm bed and haunched with concrete type ST4.

4.3.14 Concrete Protection

Where pipes exist with less than 1.2 metre cover under carriageways and 0.9 metre of cover elsewhere or where directed by the Project Engineer a reinforced concrete cover slab is required. This shall span the pipe trench and extend a minimum of 300mm both sides, widening the trench above the pipe surround, and there shall be a minimum of 150mm of surround between the crown of the pipe and underside of the slab, together with a layer of compressible material isolating the slab from the surround material

A concrete surround with flexible joints may be allowed subject to the pipe size and the flexibility required for the pipe

Where less than 700mm of cover is proposed ductile iron (to BS EN 598:2007) must be specified

Details of the Water Authority's surface water pipe protection slab requirements can be found on their website.

4.3.15 Testing of Pipelines

Where the Highway Authority will be adopting the drainage system:

Pressure tests shall be carried out on completion of every drainage run between manholes on pipes up to 750mm diameter and witnessed by the Clerk of Works.

CCTV survey may be undertaken upon request by the Project Engineer prior to Part 2 completion certificate being signed off and issued. The Project Engineer may require tests they deem necessary to be carried out before any concrete haunch or surround is placed and before any backfilling is commenced.

4.3.16 Filling Materials – Backfilling of Trenches

The backfill material must be Type 1 granular material unless it is shown that the material is compliant with class 1A, 1B, 6F1 and 6F4 of Table 6/1 of series 600 earthworks from MCHW. It should be borne in mind that the storage and use of 6F1 and 6F4 in inclement weather is likely to result in defective works.

4.3.17 Backfilling of Trenches

Backfill material as approved by the Project Engineer shall be placed in layers not exceeding 225mm in thickness and thoroughly compacted in compliance with Clause 612, MCHW. Timber and other framing shall be withdrawn ahead of the layer to be compacted, care being taken to keep the sides of the trench solid and to fill all the spaces left by the withdrawn timber.

4.3.18 Completion of Drainage

On completion of all new drains, manholes, etc the whole drainage network affected by the works shall be flushed through from end to end with water and left clean, free from obstructions and a method of protection should be arranged to stop contamination from any continuing construction.

4.3.19 Subsoil and French Drains

Where during the progress of the works agricultural drainage systems, ditches, ponds, springs or other depressions are encountered, they shall be adequately piped and connected to a suitable outfall via a suitable chamber as may be required by the Project Engineer or the Environment Agency.

Where adjacent land is higher than the highway or where deemed necessary by the Project Engineer, longitudinal drains shall be laid in trenches outside the highway boundary adjacent to the rear edge of the footway or verge. In such cases the trenches shall be completely filled with granular bedding material Type A (see Appendix A Table 7) up to the level of the top of the footway edging. Type B material may be used with the approval of the Project Engineer.

The drains shall have suitable falls and shall be connected to a positive drainage system. The form and extent of the subsoil drainage will depend upon the nature of the soil and is to be agreed with the Project Engineer after an adequate soil survey of the site.

As a minimum, land drains will normally be laid at the sides of roads in cut or where ground will slope down towards the highway on completion of the works (min. gradient 33% (1/3)) Should the Project Engineer require subsoil drainage under the carriageway this must be carried out to a special specification agreed by the Project Engineer.

4.3.20 Connections to Existing Sewers and Drains

Where connections are required to existing surface water drains or sewers such connection shall be carried out to the approval and satisfaction of the Project Engineer.

No connection shall be made to existing County Council highway drains before permission for such connection has been granted.

Where connections are proposed to the Water Authority sewers, contact shall be made with the Authority. It should be noted that land drainage systems shall not be connected such that flow discharges to a public sewer without the prior consent of the Water Authority.

4.3.21 Gully Connections

Connections from carriageway gullies to sewers and surface water drains shall be either flexible or rigid and comply with Clause 508, Table 5/2, MCHW. Maximum length of connections to be 10 metres.

4.3.22 Temporary Stoppers

Junction pipes which are laid but not immediately connected to gullies shall be fitted with temporary stoppers or seals and the position of all such junctions shall be clearly defined by means of stakes properly marked and labelled.

4.3.23 Gully Pots for Carriageways

Gully pots for carriageways shall be 450mm diameter x 900mm (minimum) deep trapped precast concrete and shall comply with BS 5911-6:2004

4.3.24 Gully Gratings and Frames

Gully gratings and frames shall be BS EN 124 Class D400 and conform to the requirements of BS 7903:1997. Gully gratings and frames shall meet the requirements of CD534.

A datasheet (or similar) to confirm that the gully grating, and frame is CD534 compliant will be required. The frame should be at least 150mm deep.

As per the requirements of BS7903, the solid bedding width of frames shall be no less than 75mm all around.

Gully gratings shall be manufactured in cast iron, ductile iron or a suitable non-metallic material of a design to reduce risk of theft e.g. hinged, recycled (but not lockable) and agreed by the Project Engineer.

CD534 includes a requirement for third party certification of gully and chamber tops such as Kitemark or similar.

Where there is pedestrian traffic as in footways and shared use highways gully gratings shall be of the “mesh” covered (pedestrian friendly) type.

Gully gratings are not to be installed by pedestrian crossing points. If such positioning is unavoidable then “mesh” covered (pedestrian friendly) gullies

must be used

4.3.25 Footpath and Cycle Track Gullies

Concrete gully pots for footpaths and cycle tracks shall comply with the requirements of BS 5911-6:2004 or plastic (UPVC) gully pots holding an appropriate BBA certificate and complying with the requirements of BS 1401 and BS EN 13598.

4.3.26 Setting of Gully Pots/ Gully Gratings/ Frames

Gully pots shall be set on a 150mm thick bed of concrete type ST4 and surrounded with a minimum 150mm of concrete of the same quality.

Gully gratings and frames shall be set abutting the kerb unit and 6mm below the plane of the finished surfacing following exactly both the longitudinal gradient and crossfall.

The frame shall be set on a high-performance bedding mortar (refer cl. 4.3.10) on 225mm engineering brickwork (min. 2 courses – max. 4 courses) built on a cover slab (thickness varies-100mm min.) such that the soffit of the gully outlet pipe is 750mm minimum below finished carriageway level and 600mm minimum elsewhere. See Clause 4.3.11 for type of Brickwork bond and Mortar laying joint

4.3.27 Catchpits, Manholes and Chambers – General

Unless otherwise specified, you must use Catchpits and not Manholes on adoptable Highway Drainage Systems

Maximum spacing between chambers shall be 100 metres. Where the depth of the chamber is less than 1.1 metres, all chambers shall be constructed with precast concrete rings in accordance with this specification. The construction of pipe lines shall be on the basis that where a change in pipe diameter occurs the pipes shall be laid with the soffits level at the manhole or chamber.

For all pipes connecting to manholes or chambers the pipe connecting to the short pipe built into the side of the manhole or chamber shall be 600mm

in length to ensure flexibility of movement.

4.3.28 Precast Concrete Manholes Chambers and Soakaways

Precast concrete manholes, chambers and soakaways shall comply with the requirements of BS 5911:2010 and BS EN 1917:2002 and to the satisfaction of the adopting authorities for water and sewers. Joints between rings shall be sealed with proprietary bitumen. Also, a 150mm concrete surround is required around the entire chamber this concrete must be sulphate resisting unless a thicker stronger chamber is used negating the need for the concrete surround.

4.3.29 Brick Manholes and Chambers

In some circumstances brick manholes and chambers may need to be used, however these will only be permitted subject to the agreement of the Project Engineer.

All bricks shall be in accordance with BS EN 771-1:2003 'Specification for masonry units. Clay masonry units' and be machine made, of uniform size, shape and colour, and free from particles of lime, pebbles or other imperfections.

Brickwork shall be in accordance with Clause 2400, MCHW and any cracked, chipped or bricks with broken arises shall not be used.

Bricks beneath frames for chambers and gullies, and for the construction of brick chambers, shall be Class B HD type engineering bricks to BS EN 771-1:2003.

See Clause 4.3.11 for type of Brickwork bond and Mortar laying joint.

4.3.30 Manhole and Chambers Covers and Frames

Manhole and chamber covers, and frames shall be BS EN 124 Class D400 in carriageways and all areas subject to vehicle traffic and class C250 in footways and verges where no vehicle traffic is anticipated.

Manhole and chamber covers, and frames shall conform to the

requirements of BS 7903:1997. Manhole and chamber covers, and frames shall be CD534 compliant.

A data sheet (or similar) to confirm that the manhole and chamber covers, and frame is CD534 compliant will be required. The frame should be at least 150mm deep. BS7903:1997 requires a solid bedding width for frames of no less than 75mm all around however some products with oversized corners may have narrower flange widths and still comply with CD534.

Where supported with a CD534 compliant data sheet, these products will be acceptable. The data sheets for these products should have a maximum bedding-pressure requirement of 2.1N/mm² combined with a flange width range of 50-120mm.

Manhole and chamber covers and frames with clear opening of greater than 1m shall comply BS 9124:2008.

Where manholes and chamber covers are placed within an area predominantly used by vehicular traffic, such as a carriageway, they shall have a minimum Polished Skid Resistance Value (PSRV) of 60.

Where manholes and chamber covers are placed within an area predominantly used by non-vehicular traffic, such as a footway, they shall have a minimum PSRV of 45.

All covers shall have identification markings to denote manhole type e.g. FW for foul sewer and SW for surface water.

All covers shall be finished in black bitumen to the satisfaction of the adopting authorities for water and sewers.

Manhole and chamber covers, and frames shall be set 6mm below finished surface level and shall follow the longitudinal gradient and crossfall. The frame shall be bedded ensuring that it is fully supported and that it does not overhang the bedding mortar at any point.

Any holes within the frame should be in-filled and the flanges enveloped by a minimum thickness of 10mm of bedding material. All exposed areas of bedding material should be float finished, ensuring voids are filled and any loose material removed.

A high-performance bedding mortar is required, being a non-shrink material with a minimum compressive strength of 30N/mm. sq within 3 hours, and a minimum tensile strength development of 5N/mm. sq within 3 hours. To gain this rate of strength development materials that fully conform to CD534 criteria are required. (Refer Cl. 4.3.10).

The inside of the frame shall be well greased before the cover is finally placed. The frames shall be set on a minimum of two courses and maximum of four courses of 225mm brickwork with any further adjustments to be agreed with the Project Engineer.

See Clause 4.3.11 for type of brickwork bond and mortar laying joint.

4.3.31 Manhole Steps

Manhole steps shall comply with the requirements of BS EN13101:2002 and to the satisfaction of the adopting authorities for water and sewers.

4.3.32 Access Ladders

Steelwork used for ladders, handholds and other fittings shall comply with BS 970 - 1 and be galvanized in compliance with Clause 1909, MCHW after fabrication. Threaded components shall be galvanized and comply with the requirements of Clause 1909, MCHW to the satisfaction of the adopting authorities for water and sewers.

4.3.33 Jointing Compounds for Chambers and Soakaways

Materials for use in jointing manholes shall be a rubber bitumen compound of approved manufacture and shall be used with the same manufacturer's primer. The dimensions of the jointing compound shall be in accordance with the manufacturer's instructions according to the size of the concrete joint section to be used.

4.3.34 Granolithic Facings

Where any benching, inverts or other profiles are to be formed with granolithic rendering they shall be made from 50kg cement, 0.035 cubic metres dry sand: 0.07 cubic metres coarse aggregate of 10mm maximum size. The water/cement ratio shall be as low as possible

compatible with workability. The screed shall be adequately protected and maintained dampened for seven days by suitably covering and water spraying.

4.3.35 Reinstatement of Adjoining Surfaces

Where any carriageway, footway, turfed, soiled or planted area of any kind has been disturbed or removed, it shall be fully reinstated with similar materials and, except in the case of turfed areas, in such additional thicknesses as the Project Engineer may direct.

4.3.36 Streams and Watercourses

Excavation carried out for digging of new open ditches, and in the diversion or enlargement of streams and watercourses, shall be performed to the satisfaction of the Clerk of Works, including the necessary trimming of slopes and grading of beds, disposal of excavated materials and all pumping, timbering works and requisites necessary for dealing with the flow of water. Approval to discharge and do works to a watercourse must be obtained from the Local Flood Authority or the Environment Agency as appropriate.

4.3.37 Soakaways and Other Infiltration Features – General

Only in exceptional circumstances will infiltration be allowed in any subsoil material other than un-weathered chalk. Soakage tests will be required in the location of each proposed soakaway unless otherwise agreed by the Project Engineer. Seasonal groundwater records may also be required to confirm that the feature always remain wholly 1 metre minimum above the groundwater table. No feature will be permitted within 6 metres of the adoptable highways or 5 metres of a building plot.

The depth of the soakaway from finished ground level shall be determined by the nature of the subsoil. Depths in excess of 3 metres will need a discharge licence from the Environment Agency. Soakage tests shall be carried out in accordance with BRE Digest 365 (Soakaway Design 2007 revision) to simulate the proposed feature dimensions and shall be performed in the presence of the Project Engineer if so required. The method of test and interpretation of results shall be to the approval of the Project Engineer.

If during the period of maintenance any feature is found to have inadequate capacity or soakaway rate, then the Developer will have to provide an alternative system of drainage at his own expense.

4.3.38 Precast Concrete Soakaways

All rings below the invert shall be perforated in compliance with BS 5911-3:2010 but the maximum diameter of perforation shall be 75mm.

The soakaway shall be surrounded with approved free draining material or similar approved material up to the top of the perforated rings and shall have a 150mm suitable backfill surround for the remaining depth.

4.3.39 Ponds, Wetlands, Detention/Infiltration Basins and Swales

Excavations are to be carried out to the lines, levels and dimensions shown on the approved drawings or to such other levels and dimensions as may be directed by the Project Engineer. Any materials imported shall be tested and must comply with required British Standards. All inlet and outlet structures are to be approved by the Project Engineer and where necessary materials are to be independently tested and the results given to the Project Engineer for acceptance.

All features are to be kept clean from construction detritus and should not be used until the contractor has completed all building works. Any damage would be required to be rectified including features that have been adopted in previous phases of a development which become contaminated.

4.3.40 Geocellular Storage

Geocellular storage is to be installed to the manufacturer's specification. Only the system stated on the drawings may be used unless agreed with the Project Engineer. The excavation is to be inspected prior to installation of the crates and prior to backfilling by the contractor. Before they are adopted the storage must be flushed through and left free of obstructions.

4.3.41 Permeable Paving

Permeable Paving would generally not be permitted in the public highway and its use will only be considered in 'exceptional circumstances' and with

the approval of a Senior Member of the Development Management Team. It will also attract a commuted sum.

The paving shall be laid to the depths as on approved drawings. The blocks shall be an 80mm block and shall comply with BS EN 1338. The laying course granular material shall comply with BS 7533:3 and shall be independently tested for compliance.

The granular material shall be compacted so that it forms a stable mass with a suitable compaction device so as not to crush the material.

The geo-textile shall be to BS 7533:13 and where not wide enough to cover the whole excavation shall be joined/ overlapped as per the approved drawings.

Once laid the granular material shall not be run on and shall be kept clean and free of contamination. If run on the Clerk of Works shall insist that all the granular material is cleaned/replaced.

If a bituminous layer is applied to allow running on this, it shall be drilled prior to laying the blocks and shall not be run-on until completion of the block paving. The bitumen layer shall be cored with 75mm holes in a 0.75 metre grid and shall be filled with the laying material.

Once the final block work is installed construction vehicles should not use the road as contamination would result in a requirement for the developer to remove the contamination in its entirety for the complete depth of the carriageway.

4.4 Footways, Footpaths, Cycle Tracks and Service Strips

4.4.1 Compaction of Trenches

All services within the highway limits shall be laid and the trenches properly backfilled with approved material and compacted before any works are commenced.

4.4.2 General Preparation

Before any works are commenced the whole of the area between the highway boundary and the edge of the carriageway or kerb shall be levelled

and thoroughly compacted by means of a 305/355 kg vibrating roller or other approved machine. For most soils other than silt, the CBR of the subgrade at the time of construction will be at least 2.5%.

4.4.3 Preparation of Formation

The formation shall be properly cleaned free from mud and slurry and properly shaped and compacted by rolling to the satisfaction of the Project Engineer. Weedkiller shall be applied to the formation by certified personnel but not to be used on ground in which the roots of trees are growing or are to be planted unless approved by the Project Engineer.

If required and where directed by the Project Engineer a 'sacrificial' granular layer 75mm thick shall be provided in addition to the sub-base for any vehicles using the way as a route across/through the site.

4.4.4 Soft Spots

Any soft or unstable areas in the formation shall be tested in accordance with the requirements of BS 1377. Any material failing the tests shall be excavated and replaced with approved material and compacted in accordance with Clause 802, MCHW. All excavated material shall be disposed of off-site and not reused.

4.4.5 Precast Concrete Edging

Edging to footways, footpaths, cycle tracks and service strips shall be provided in most cases. The edgings will normally form the boundary of the highway and shall be made continuous across private accesses. Where the footway, footpath, cycle track or service strips abuts directly against garden walls or similar structures, the edging need not be provided. The precast concrete edging shall be bedded on 150mm of concrete and haunched to within 50mm of the top whilst the concrete type is still plastic and workable. The concrete type shall be a standard type ST1 complying with BS 8500 - 1 and Clause 2602, MCHW.

In instances where a block paved surface abuts block paving within private areas it is acceptable to omit the edging in favour of a double row of stretcher course blocks; the centre joint being the limit of adoption/demarcation (where appropriate and within control of the Developer).

4.4.6 Sub-Base

Sub-base for footways, footpaths, cycle tracks and service strips shall consist of granular material Type 1 to Clause 803, MCHW. The material shall be laid and compacted in accordance with Clause 802, MCHW. Material laid in extremely restrictive areas shall be compacted with a suitable vibrating plate compactor.

4.4.7 Surfacing

Surfacing for footways and paved areas shall be laid true to levels, crossfalls and thickness as described on the drawings.

For construction materials please refer to Appendix A Table 5.

4.4.8 Pram/Wheelchair Crossings

Pram/wheelchair crossings shall be provided where indicated on the drawings or as directed by the Project Engineer and shall consist of a minimum of two type BN kerbs (kerb upstand 0-6mm) with two ramped kerbs to BS EN 1340 types DL1/DR1.

The rear edging of the footway shall be ramped and dropped correspondingly with the road kerb if the permitted footway gradients cannot be achieved.

No gullies shall be constructed adjacent to crossings.

4.4.9 Vehicle Crossings

Strengthened footways, footpaths, cycle tracks and service strips will be required where motorised vehicles will be expected to park or pass (e.g. vehicle crossings, vulnerable footways/paths requiring the passage of maintenance and/or emergency vehicles).

Vehicle crossings shall be formed of the width and in the positions indicated on the drawings. Single crossings shall consist of a minimum of four type BN kerbs – maximum of five type BN kerbs (kerb upstand 15-25mm) with two ramped kerbs to BS EN 1340 types DL1/DR1; shared crossings should have a maximum of eight type BN dropped kerbs (kerb upstand 15- 25mm) with

two ramped kerbs to BS EN 1340 types DL1/DR1.

The rear edging of the footway shall be ramped and dropped correspondingly with the road kerb if the permitted footway gradients cannot be achieved.

Where possible no utility covers/boxes shall be installed within a vehicle crossing area, however, if this unavoidable, suitable heavy-duty covers shall be used. No gullies shall be constructed adjacent to crossings.

In some circumstances, where overrunning of grass verges by vehicles, or where other problems are anticipated, verges of an agreed hard construction may be required by the Project Engineer.

4.4.10 Precast Concrete Tactile Paving

Precast concrete flags for tactile paving shall be hydraulically pressed and comply with the requirements of BS EN 1339. The flags shall be appropriately coloured pink, buff or grey and be either 400 or 450mm square x 65mm thick. Choice of paving size to suit site requirements in order to reduce the amount of cuts.

Tactile paving slabs shall only be provided on road types A-D (as defined in the Essex Design Guide) and be installed in accordance with “Guidance on the use of tactile paving surfaces” published by DfT.

The slabs shall be laid on maximum 30mm thick clean sharp sand bed and the adjacent surfacing materials shall be dressed flush with the top flat surface of the slabs. In areas of likely wheel loading, reinforced paving slabs laid on a mortar bed should be used. Base materials beneath paving to be in bituminous in accordance with Appendix A Table 5. The locations, size, colour and patterns shall be as detailed on the approved drawings.

The alignment of the tactile paving slabs at crossings is critical and the Developer must inform the Clerk of Works when they are being installed so they can inspect during construction.

4.4.11 Precast Concrete Flag Paving

Precast concrete flag paving in accordance with BS EN 1339:2003. Generally installed in modules 900 x 600mm or 600 x 600mm and 50mm

thick. Laid as CI 4.4.10

4.4.12 Hard Landscaping

Where an overrun is anticipated these areas should be adequately hard landscaped in colour/type to the approval of the Project Engineer.

Any sight splays to driveways should be hard landscaped in the same material as the driveway.

4.4.13 Statutory Undertakers Covers and Frames

All statutory undertakers' covers and frames for clear openings 450 x 450mm or smaller shall conform to the requirements of BS 5834-2:2011, 'Surface boxes, guards and underground chambers for the purpose of utilities. Specification for surface boxes' and not to be located within vehicle crossings. If this is unavoidable, covers shall be heavy duty type and fit for purpose.

Covers and frames within footway areas shall be installed to the rear of the footway as far from the carriageway kerb edge as possible.

4.5 Kerbing and Channelling

4.5.1 Precast Concrete Kerbs, Channels, Edgings

Precast concrete kerbs, channels and edgings shall be hydraulically pressed and conform to BS EN 1340. The dimensions, type designations, performances and classes shall comply with the requirements of Clause 1101, MCHW.

Purpose made ramps and dropped kerbs shall be used at vehicle crossings.

Special kerbs, channel blocks and quadrants shall only be used when approved by the Project Engineer. An alternative recycled/composite kerb with BBA certification with the approval of the Project Engineer may be used.

Type HB2 kerbs shall be laid to provide a 100mm kerb upstand, except on a bus route, where the kerb upstand should be 125mm, unless otherwise

agreed in writing with the Development Management Project Engineer. If used to provide a dropped course at vehicle crossings, kerbs shall be type BN laid to provide an upstand of 15-25mm unless directed otherwise by the Project Engineer.

Special ramped or taper kerbs shall be used to accommodate the difference in kerb face at crossings.

The correct radius kerbs shall be used for all radii that are 12m or less.

900mm internal radius kerbs shall be used where kerb lines would otherwise meet at right angles. Alternatively, internal or external angle kerbs and straight kerbs may be permitted with the approval of the Project Engineer.

No kerbs shall be laid that are less than 300mm in length.

4.5.2 Combined Kerb and Drainage Units (CKD)

Precast concrete combined kerb and drainage units shall conform to BS EN 1433:2002. An alternative recycled/composite kerb drain unit with BBA certification with the approval of the Project Engineer may be used.

4.5.3 Granite Setts

Granite setts shall generally have a 100mm x 200mm cross section and be fair face on any exposed surface; rectangular in shape and shall comply with the requirements of BS EN 1342 2012.

4.5.4 Kerb Foundations

All kerbs shall be set on an in-situ concrete bed and haunched. The bed and haunching concrete shall be thoroughly compacted and the kerbing shall be bedded and haunched whilst the concrete type is still plastic and workable.

Where forms are used to retain the concrete bed, these shall be clean, and oiled or greased, be of an approved pattern and rigidly supported. The forms shall be carefully set out to the required line and levels and shall be removed not less than 24 hours after compaction of the concrete. If the face of the carriageway excavation is used as the outer shuttering for the

concrete, this shall be trimmed vertically and to correct line.

Where the Developer does not wish to provide a permanent edge restraint before the laying of the carriageway or footway, an approved temporary form of edge restraint may be used.

Temporary edge restraints are to remain in position and shall be inspected before the permanent restraint is laid.

No traffic shall run on any section of road previously constructed until such time as an edge restraint has been provided.

4.5.5 Kerb Lines

Kerb and channel lines shall be properly set out to the lines and levels given on the approved drawings. The kerbs and channels shall be laid accurately to these lines and any fine adjustments made so that a smooth flowing alignment is achieved free from sudden deviations in line and level.

4.5.6 Damage to Kerbs

Should any damage be done to existing or new kerbing during the execution of the works, the whole length affected shall be taken out and made good to the satisfaction of the Project Engineer. Any kerb unit deviating more than 3mm in 3 metres from line and level shall be made good by lifting and relaying.

4.6 Carriageway Construction (Flexible)

4.6.1 Order of Works

All drainage works, statutory undertaker's cabling/pipes and utilities ducts shall be installed before the carriageway construction is commenced. All trenches and pits shall be backfilled in accordance with this manual.

The Highway Authority will not accept any trench working into the base course layer or above. The Developer should consider using a reduced base layer thickness as a 'sacrificial' running surface before completion of the final construction layers.

4.6.2 Formation Preparation

Where the laying of the sub-base does not immediately follow the preparation of the formation, the formation shall be prepared again by removing any water, dust, loose or deteriorated material, regrading with granular fill material approved by the Project Engineer and compacting by rolling.

4.6.3 Granular Sub Base Type 1

Granular sub-base material Type 1 shall comply with Clause 803, MCHW – Type 1 Unbound Mixtures. The mixture shall comply with BS EN 13285 and the requirements from table 8/1 with grading requirements to table 8/5 and must be used in conjunction with a geotextile membrane for a subbase only pavement foundation design.

4.6.4 Recycled Materials

All recycled materials used within the works shall be tested by a UKAS laboratory and have the relevant certification endorsements and be approved by the Project Engineer.

4.6.5 Geosynthetics

Geotextiles, geogrids, geomembranes etc. to BS EN 13249:2016 'Geotextiles and geotextile-related products. Characteristics required for use in the construction of roads and other trafficked areas shall be permitted for use within the works to the approval of the Project Engineer.

4.6.6 Laying the Sub-Base

The sub-base material shall be spread evenly to the required profile and total thickness shown on the drawings.

The sub-base material shall be compacted in layer thicknesses suitable for the type of compaction machinery to be employed. For light hand-held machinery the layer thickness shall not exceed 100mm after compaction.

For heavy machinery the layer thickness shall not exceed 150mm after compaction. Should segregation take place during spreading causing areas of coarse stone, these shall be blinded with stone fines during

compaction.

During compaction the surface profile shall be corrected by hand and trimmed so that when finished, it is within a tolerance of plus 10mm to minus 30mm of the proper surface profile.

4.6.7 Asphalt Concrete

All asphalt concrete shall be obtained from an approved supplier and shall conform in all respects to BS EN 13108 - 1 Asphalt Concrete (Bitumen Macadam).

4.6.8 Hot Rolled Asphalt

All hot rolled asphalt shall be obtained from an approved supplier and shall conform in all respects with BS EN 13108 - 4 Hot Rolled Asphalt.

Hot rolled asphalt surface course design mixes shall have a minimum stability of 5kN and a maximum flow of 5mm. Full design details shall be submitted to the Project Engineer for approval.

The minimum polished stone value (PSV) of the course aggregate shall be 55 unless specified otherwise. For non-chipped (55/10) high stone content HRA the Polished Stone Value (PSV) and Aggregate Abrasion Value (AAV) must be specified in the design and shall comply with the requirements of the DMRB, Volume 7, Section 5, Part 1 - HD36/06 and Interim Advice Note 156/12 – Revision of Aggregate Specification for Pavement Surfacing

Pre-coated chippings shall be either 14 or 20mm nominal size complying with the relevant requirements of BS EN13108. The Polished Stone Value (PSV) and Aggregate Abrasion Value (AAV) must be specified in the design and shall comply with the requirements of the DMRB, Volume 7, Section 5, Part 1 HD 36/06.

For 55/10 HRA the minimum average texture depth following the wearing off of the surface binder and exposure of the surface aggregates should be 0.5mm.

For chipped HRA, the rate of spread for applied chippings shall be uniform throughout the site and shall be sufficient to achieve a texture depth as detailed in MCHW, Series 900 Table 9/3 'Requirements for Initial Texture

Depth for Trunk Roads including Motorways'. Texture depth shall be determined by the volumetric patch method complying with BS EN 13036-1:2010 using the procedures outlined in BS 594987 Clause 8.2.

4.6.9 Thin Surface Course Systems (TSCS)

Thin Surface Course Systems shall fully comply with Clause NG 942, Clause 942 MCHW and Interim Advice Note 157/11. The Polished Stone Value (PSV) and Aggregate Abrasion Value (AAV) must be specified in the design and shall comply with the requirements of the DMRB, Volume 7, Section 5, Part 1 HD36/06.

4.6.10 High Friction Surfacing

Where a new surface course is being laid, our preference will be for a high PSV surface of 68 rather than the use of high friction surfacing.

High Friction Surfacing is primarily installed to reduce the risk of skidding. All requirements for the supplying and laying of the surface material must meet the specifications as detailed in Clause 924 MCHW.

Typical areas of use are on the approaches to:

- Pedestrian crossings
- Signal controlled junctions
- Roundabouts (inc. mini roundabouts)
- Bends

Calcined Bauxite is recommended with the buff or grey coloured type being generally used.

4.6.11 Transporting, Laying and Compaction – General

Bituminous materials (including Asphalt Concrete, Hot Rolled Asphalt and Stone Mastic Asphalt) shall be transported, laid and compacted in accordance with BS 594987:2010

4.6.12 Laying Bituminous Materials

The surface on which material is to be laid shall be clean and free from mud, slurry, ice, standing water and any other harmful material.

Laying shall be suspended during periods of continuous heavy rain or when

pools of water are becoming evident. Any previous layer shall be compacted using a roller exerting at least as great a load per unit width of roll as that to be used for rolling the bituminous material. Wherever practical materials shall be spread, levelled and tamped by an approved self-propelled laying machine.

As soon as possible after arrival on site the mixed material shall be supplied to the paver and laid without delay. The rate of delivery of the material to the paver shall be so regulated as to enable the paver to be operated continuously and it shall be so operated whenever practicable.

The rate of travel of the paver and its method of operation shall be adjusted to ensure an even and uniform flow of material across the full laying width, freedom from dragging or tearing and without segregation of the material. The material shall be laid in compliance with the requirements and recommendations for laying in the appropriate British Standard.

Hand laying of bituminous material shall be avoided wherever possible and only undertaken with the prior approval of the Project Engineer.

4.6.13 Compaction of Bituminous Materials

Bituminous material shall be laid and compacted in layer thicknesses which enable surface level and regularity requirements to be met and adequate compaction to be achieved. The maximum thickness of material laid in one pass of the paver shall be limited so as to ensure adequate compaction and surface regularity.

Material shall be rolled uniformly as soon as rolling can be put in effect without causing undue displacement of the mixed material and shall be substantially completed whilst the temperature of the mixed material is greater than the minimum rolling temperature stated in the appropriate British Standard.

Rolling shall continue until all surface roller marks have been removed.

Compaction shall be carried out using 8-10 tonnes deadweight smooth wheeled rollers having a width of roll of not less than 450mm, or by multi-wheeled pneumatic tyred rollers of equivalent mass, or by vibratory rollers or a combination of these. Surface course and binder course materials

shall always be surface finished with a smooth wheeled roller which may be a dead weight roller or alternatively a vibratory roller in non- vibrating mode. Vibratory rollers shall not be used on bridge decks.

The material shall be rolled in a longitudinal direction with the driven rolls nearest the power. The roller should first compact the material adjacent to any joints and then work from the lower to the upper side of the layer overlapping on successive passes by at least half the width of the rear roll or in the case of a pneumatic tyred roller, at least the normal width of one tyre.

Where requested by the Project Engineer the level of compaction shall be determined by drilling and testing core samples. The mean bulk density and the total air voids shall be determined in accordance with Clause 929, MCHW and the efficiency of compaction shall be such that the mean total air voids for any consecutive six cores shall not exceed 7% in the case of coated macadam and 5% in the case of hot rolled asphalt.

Additionally, the air voids in any individual core shall not exceed 10% for coated macadam and 8% for hot rolled asphalt.

The areas represented by these high individual results shall be fully investigated in order to identify their extent.

As an alternative to assessing the efficiency of compaction by determining air voids, the Project Engineer may allow Percentage Refusal Density Tests (PRD) on coated macadam. This test may be appropriate where:

- The suspect area is small
- The suspect area was hand laid
- The material was supplied by a number of plants with varying types of aggregate
- The results are needed urgently
- There is no available information on the source and physical properties of the aggregates.

If (PRD) is used as a basis for assessing compaction the refusal density of the material under test shall not be less than 93% of the theoretical mix density.

For assessing compaction of large areas, the Project Engineer may permit the use of a suitably calibrated indirect density gauge. In cases of dispute however precedence shall be given to the densities obtained from core samples. The Developer shall paint the walls and base of all holes, from which cores have been cut, with hot penetration bitumen and fill with material approved by the Project Engineer.

4.6.14 Bond Between Bituminous Layers

Bond coats shall be applied between bound layers of bituminous materials by metered mechanical spraying equipment, spray tanker or spraying device integral with the paving machine. Bond coats shall have a BBA certification and comply with Clause 920, Volume 1, MCHW.

There shall be sufficient adhesion between successive layers of bituminous materials to form a bond between layers.

The presence and strength of a bond can be determined by coring. Successive layers of bituminous materials should not shear off when drilling a 150mm core vertically through the construction. If this occurs it could be indicative of insufficient bonding and the area shall be investigated further. The interface between layers should also be dry and free from dirt mud and other harmful materials.

The application of a bond coat on a clean dry surface together with the materials being at the right temperature will promote adhesion between successive layers, provided that the bond coat is given time to break.

4.6.15 Statutory Undertakers Covers and Frames

Refer to paragraph 4.4.13

4.7 Concrete General

4.7.1 Cement Bound Material

Cement bound material shall comply with Clause 1001, Table 10/1, MCHW and shall be laid, transported, compacted and cured in accordance with Clause 1030, MCHW.

4.7.2 Cement

Ordinary Portland Cement and rapid hardening Portland Cement shall comply with the requirements of BS 12 (no longer current but cited by Building Regulations) “Specification for Ordinary and Rapid-Hardening Portland Cement”. Sulphate resisting cement shall comply with the physical requirements of BS 4027:1996 “Specification for Sulphate Resisting Portland Cement”.

White or coloured cement shall be of approved quality and chemical composition and shall comply with the physical requirements of BS EN197 – 1:2000 Cement. Composition, specifications and conformity criteria for common cements (AMD 15209) BS 12 (no longer current but cited by Building Regulations).

Cement shall be stored in a dry weather proof shed with a raised wooden floor, or in a silo and shall be delivered in quantities sufficient to ensure that there is no suspension or interruption of the work of concreting at any time and if in sheds each consignment shall be kept separate and distinct. Any cement which shall have become injuriously affected by damp or other causes shall at once be removed from the site.

The Developer shall furnish as directed by the Project Engineer test certificates relating to the cement to be used on the works. Each certificate shall indicate that the sample has been tested and analysed by an approved firm and that it complies in all respects with the requirements of the appropriate BS for the particular type of cement.

2.7.3 Aggregates for Concrete

Aggregates for concrete shall consist of naturally occurring materials complying with the requirements of:

BS EN12620: 2002 - Aggregates for concrete (AMD Corrigendum 15333)

BS 882:1992 - Specification for Aggregates from Natural Sources for Concrete (no longer current but cited by Building Regulations) and

PD6682/1:2009 – Guidance on the use of BS EN 12620 - Aggregates for Concrete.

A certificate of compliance with the relevant BS shall be provided by the Developer.

All aggregates brought onto the site shall be kept free from harmful matter and aggregates of different sizes shall be stored in separate stacks.

Coarse aggregate for concrete shall be clean gravel or other hard stone graded 40mm to 5mm or 20mm to 5mm complying with BS EN12620: 2002 Aggregates for concrete (AMD Corrigendum 15333).

Fine aggregate for concrete shall be gravel, sand or natural sand conforming to BS EN12620: 2002 Aggregates for concrete (AMD Corrigendum 15333).

“All in” aggregate for concrete shall be a combination of fine and coarse aggregates conforming to BS EN12620: 2002 Aggregates for concrete (AMD Corrigendum 15333)

Coarse aggregate for granolithic concrete shall be crushed granite as specified in BS EN12620: 2002 Aggregates for concrete (AMD Corrigendum 15333) (maximum size 10mm).

4.7.4 Water

Water for making concrete or mortar shall be obtained from the public mains with the approval of the appropriate supplying authority.

4.7.5 Concrete Strengths

Where specified for use all ready mixed concrete mixes shall comply with Concrete - Complementary British Standard to BS 8500-1:2006 - Method of specifying and guidance for the specifier.

Ready mixed concrete production plants shall operate under the “Quality Scheme for Ready Mixed Concrete” or similar quality assurance scheme. The expected characteristic compressive strength of cubes manufactured from various BS EN206 mixes when tested at 28 days in accordance with BS 1881 can be found in BS 8500 - 1:2002.

Typical uses for concrete for ancillary purposes are defined in Appendix A Table 8.

4.7.6 Water Cement Ratio

The water/cement ratio shall be as low as possible consistent with a workable concrete and shall not exceed 0.55 taking into account any free surface water in the aggregates.

4.7.7 Higher Strength Concrete

If the concrete is required for structural work which necessitates a greater cube characteristic strength than 25.0 N/mm² then the mix shall be designed in accordance with BS EN 206-1:2000.

If directed by the Project Engineer, the Developer shall carry out trial mixes with the proposed materials.

4.7.8 Workability of Concrete

The concrete shall be of suitable workability for full compaction to be achieved with the equipment used and without undue flow.

4.7.9 Admixtures other than Air Entraining Agents

The use of plasticisers or water reducing agents or other admixtures shall not be permitted without the written consent of the Project Engineer. If used, they shall conform to BS EN 480. Accelerating admixtures and those containing calcium chloride shall not be used.

4.7.10 Dowel Bars

Dowel bars shall be grade B500B steel complying with BS EN 13877 - 3:2004 and shall be free from oil, dirt, loose rust or scale. They shall be straight, free of burrs or other irregularities and cropped cleanly with no protrusions outside the normal diameter of the bar. For expansion joints, dowel bars shall be 25mm diameter and for contraction joints the dowel bars shall be 20mm diameter for slabs up to 239mm thick. Their length shall be 600mm long @ 300mm spacing for expansion joints and 400mm long @ 300mm spacing for contraction joints.

4.7.11 Tie Bars

Tie bars shall be Grade B500B steel or Grade B500C to BS 4449 and shall be free from oil, dirt, loose rust or scale. Tie bars needing to be cranked for subsequent straightening shall be mild steel. Tie bar dimensions shall be

as stated in Clause 1012, Table 10/5, MCHW.

4.7.12 Steel Reinforcement

Steel reinforcement shall comply with any of the following standards and be in prefabricated sheets or bars assembled on site and shall be free from oil, dirt, loose rust or scale.

- Steel fabric in flat bars BS 4483
- Hot rolled steel bars Grade B500B BS 4449
- Hot rolled steel bars Grade 460 BS 4449
- Cold worked steel bars BS 4449

When deformed bars are used they shall conform to type 2 bond classification of BS 4449.

4.7.13 Curing Compounds

Immediately after completion of the surface treatment, the surface, exposed edges and surface slabs shall be cured by the application of an approved resin based aluminised curing compound, polythene sheeting or an approved sprayed plastic film which hardens into a peelable plastic sheet that is removed before road markings and open to traffic.

Resin based aluminised curing compound shall contain sufficient flake aluminium in finely divided dispersion to produce a complete coverage of the sprayed surface with a metallic finish. The compound shall become stable and impervious to evaporation of water from the concrete surface within 60 minutes of application and shall have an efficiency index of 90%.

The curing compound shall not react chemically with the concrete to be cured and shall not crack, peel or disintegrate within a period of three weeks after application.

4.7.14 Pre-Formed Joint Filler

Preformed joint filler shall be of the thickness described on the agreed Project Engineering drawings within tolerance of $\pm 1.5\text{mm}$ and shall comply with Clause 1015 MCHW and in suitable lengths, each no less than 1.2 metres. Holes to accommodate dowel bars shall be accurately bored or punched out to be a sliding fit on the dowel bars.

The material comprising joint filler shall be of such quality that it can be satisfactorily installed in position at the joint.

Certificates that the material has complied with the tests described in Clause 1015 MCHW shall be supplied by the Developer.

4.7.15 Joint Sealant and Seals

Joint sealants and seals shall consist of hot poured compounds and shall comply with BS 2499-2:1992 - Hot Applied Joint Sealants for Concrete Pavements - A Code of Practice for the Application and Use of Joint Sealants.

4.8 Carriageway Construction (Rigid)

4.8.1 Sub-Base Layer

The sub-base layer for rigid carriageway construction shall be granular sub-base material Type 1 in accordance with Section 4 Clause 4.6.3.

4.8.2 Waterproof Underlay

An underlay as specified in Clause 1007, MCHW shall be used to provide a waterproof membrane between the concrete slab and the sub-base. Waterproof membranes shall consist of impermeable plastic sheeting not less than 125 microns thick. Where an overlap of the underlay material is necessary the overlap shall be at least 300mm.

Water shall not be allowed to pond on the membrane which shall be completely waterproof when the concrete is laid.

4.8.3 Construction of Formwork

Formwork shall include temporary or permanent forms required for forming the concrete together with all temporary construction required for their support. All formwork shall be so constructed that there shall be no loss of material from the concrete. The formwork shall be of a quality to ensure that the finished concrete is as described on the drawings. Where no edge restraint is provided before laying of concrete roads, steel side forms shall be set to line and level supported throughout their entire

length. The forms shall be straight with a tolerance of 3mm per 3m length. They shall be secured in position so as to be sufficiently rigid to obviate any movement during the process of laying and compacting the concrete on a bed of low moisture content cement mortar or grade ST1 concrete. The bedding shall not extend under the slab and the surface levels shall accord with the approved Project Engineering drawings with a tolerance of ± 3 mm including steps between adjacent forms.

The horizontal alignment shall similarly be to a tolerance of ± 10 mm. The mortar or concrete bedding to be broken out and removed on completion.

All mortar and harmful material shall be removed from steel forms which have been previously used and the forms shall be greased or oiled before fresh concrete is deposited against them.

Forms must not be removed until the expiration of at least 24 hours after the placing of concrete. In those cases where timber forms have been used, removal shall take place not sooner than 24 hours after placing the concrete but no later than 48 hours thereafter. Forms shall be drilled to accommodate tie bars.

4.8.4 Pavement Quality Concrete

Concrete may be mixed on or off site in accordance with the requirements of BS 8500:2006

Pavement quality concrete shall be a design type to Grade C32/40 air entrained in accordance with Clause 1002, MCHW.

The concrete design shall be submitted to the Project Engineer prior to work commencing and trial types may be required to substantiate the design data. If ready mixed concrete is used, evidence of the sufficiency of the design shall be obtained from the suppliers. Similar information shall be required in respect of site mixed concrete. The mass of cement incorporated in each cubic metre of fully compacted concrete shall not be less than 320 kg.

4.8.5 Air Entraining Agents

The pavement quality concrete used shall contain an air- entraining agent in sufficient quantity for the total entrained air content of the concrete.

4.8.6 Mixing Concrete

The weighing and water dispensing equipment shall be maintained in good order. Their accuracy shall be maintained within the tolerances described in BS 1305 or tested in accordance with BS 3963 and shall have a mixing performance within Table 6 of BS 1305. Where appropriate, the batch capacity method of loading, mixing time and drum speed shall confirm to the details furnished in accordance with the requirements of BS 3963 for the mix proportions being used.

The mixing blades of pan mixers shall be maintained to the tolerances specified by the manufacturer of the mixer and the blades shall be replaced when it is no longer possible to maintain the tolerances by adjustment.

Mixers which have been out of use for more than 30 minutes shall be thoroughly cleaned before any concrete is mixed.

Concrete mixing shall not be carried out at temperatures below 1°C on a rising thermometer or below 3°C on a falling thermometer nor during any time that the ingredients or the base on which the concrete is to be placed are frozen.

Sufficient quantity of air entraining agent shall be added to the mix for the total air entrained air content of the concrete to comply with Clause 1001 and 1002, MCHW.

4.8.7 Ready Mixed Concrete

Ready mixed concrete shall be permitted for use if it conforms to the requirements as defined in BS 8500-1:2006.

The concrete shall be carried in purpose made agitators, operating continuously or in truck mixers. The time of such introduction of water to the mix shall be recorded on the delivery note together with weight of the constituents of each mix.

When truck mixed concrete is used, water shall be added under supervision, either at the site or at the central batching plant as agreed with the Project Engineer, but under no circumstances shall water be added in transit.

Unless otherwise agreed with the Project Engineer, truck mixer units, their

mixings, discharge performance, the number and rate of revolutions for a specific concrete type shall comply with the requirements of BS 1305:1974.

4.8.8 Workability

Workability of concrete shall be determined by a slump test in accordance with BS 12350-2:2009 and carried out at the point of placing. The workability shall be maintained at the optimum within the limits specified in BS EN 206-1.

4.8.9 Transporting and Placing Concrete

Concrete shall be transported and placed so that contamination, segregation or loss of constituent materials does not occur.

The concrete shall be spread in two layers, the first layer shall be spread to such a level that after subsequent compaction it will support the reinforcement at the required depth below the finished surface level when placed upon it.

The layer of reinforcement shall then be immediately covered with concrete.

The placing, compacting and finishing of the concrete shall be carried out as rapidly as possible and the operations shall be so arranged that the time for completion of the mixing of the first batch of concrete in any transverse vertical section of the spraying of the curing membrane on that section shall not exceed those given in the table below.

Temperature of Concrete	Maximum time from mixing to finishing the Concrete
Not more than 25°C	3 hours
Between 25°C and 30°C	2 hours
Over 30°C	No concreting

When the temperature of the concrete at the spreader or hopper box is over 30°C concreting shall cease.

4.8.10 Concrete Carriageways

The carriageway slab concrete shall be grade C35/40 air entrained. The concrete of each course shall be spread with the surcharge necessary to produce, when thoroughly compacted, the overall thickness as specified.

The deposition of concrete shall be continuous between expansion joints and at no point shall the compacted concrete be of less thickness than specified. Compaction and finish shall be by a vibratory beam or mechanical tamper of an approved steel shod inset type which shall be capable of compacting the whole width of the bay for the full thickness of the slab. Where a self-propelled vibrating machine is used it shall be fitted with a front screed for striking off the concrete at a sufficient height to allow for proper compaction. Additional vibration at the edges of the slab shall be carried out by a poker vibrator.

4.8.11 Expansion Joints

Expansion joints shall comprise of vertical preformed joint filler board, dowel bars and supporting cradles or assemblies. Joint assemblies and filler boards shall be within a tolerance of $\pm 10\text{mm}$ from the true line of the joint.

The joint filler shall comply with the requirements of Clause 1015, MCHW and be sufficiently rigid to enable it to be satisfactorily installed in the joint. It shall resist deformation during the placing of the concrete and shall be installed with sufficient accuracy that its upper surface lies at such a depth below the surface as to allow the depth of the seal as given in Clause 1016, MCHW. Softwood expansion joint filler shall be immersed in water for 48 hours and kept damp until the concrete is placed around it. The joint filler together with the seal shall provide complete separation of the adjacent slabs and loose-fitting holes around dowel bars and spaces between the sub-base and the filler board shall be packed with joint filler material after assembly of the joint.

Dowel bars shall be provided, within a tolerance of $\pm 20\text{mm}$ at the mid depth of the slab. When supported in assemblies or cradles and positioned prior to concreting, the bars shall be parallel to the finished surface of the slab and to the centre line of the carriageway within the tolerance of $\pm 3\text{mm}$.

Dowel bars shall be equally positioned about the centre line of the joint

within a tolerance of ± 25 mm.

Dowel bars shall be provided at one end with a closely fitting cap 100mm long consisting of waterproofed cardboard of an approved synthetic material. An expansion space equal in thickness to that of the joint filler or a pad of cotton waste. The cap shall be placed on the free half of each dowel which shall also be coated prior to concreting with bond breaking compound or sheath complying with Clause 1011, MCHW.

The assembly of joint filler, dowel bars and supporting cradles when fixed in position shall be entirely rigid.

4.8.12 Longitudinal Joints

Longitudinal joints incorporating tie bars shall be provided, as indicated on the approved Project Engineering drawings and C8, Volume 3, section 1, MCHW. Generally, tie bars placed at 0.6m spacings with each bar being 0.75m long (max).

4.8.13 Steel Reinforcement

The reinforcement shall be so placed that after compaction of the concrete, it is located within ± 10 mm of the level indicated on the Project Engineering drawings and it terminates 125mm ± 25 mm from the edges of the slab.

Reinforcement shall be positioned above the dowel bars and tie bars irrespective of the tolerances on position.

Where overlapping of reinforcement is necessary longitudinally, the overlap shall not be less than 35 times bar diameters (or 450mm whichever is greater) and transversely not less than 300mm. All overlaps shall be securely tied by steel wire.

4.8.14 Surface Finish

The surface finish of the slab shall be achieved in accordance with Clause 1026, MCHW.

4.8.15 Channels and Joints

The arises of joints shall be rounded with a nosing trowel to a 10mm radius.

Channels shall be finished by floating with a steel trowel for a 300mm wide strip adjacent to the kerb.

4.8.16 Compaction of Concrete

All concrete shall be compacted to produce a dense homogeneous mass; it shall be compacted with the assistance of vibrators. Sufficient vibrators in serviceable condition shall be on site so that spare equipment is always available in the event of breakdown. Internal vibrators shall be capable of producing not less than 10,000 cycles per minute. Vibration shall not be applied by way of reinforcement. Where vibrators of the immersion type are used, contact with reinforcement and all inserts shall be avoided as far as is practicable. Concrete shall not be subject to vibration from adjoining works between 4 and 24 hours after compaction.

The density achieved shall be in accordance with Clause 1003, MCHW and strengths shall be tested in accordance with BS 8500:2006

4.8.17 Protection of Concrete Bays

Immediately after compaction and for seven days thereafter, concrete shall be protected against the harmful effect of weather, including rain, rapid temperature changes, frost, and from drying out as recommended in Clause 1027, MCHW.

Failure to do so and which results in defects of any description will mean the entire bay being broken out and replaced.

No tamping shall take place off the support of completed bays for at least seven days after placing and no traffic whatever shall be permitted on the completed bays for at least 14 days after completion.

A further delay of one day shall be added to the foregoing period of restriction for each night when the surface temperature of the layer falls to 0°C or below.

4.8.18 Curing

The exposed surface of concrete pavement shall be cured immediately after finishing by treating with an approved aluminised curing compound. It shall be mechanically sprayed on at a rate of 0.22 – 0.27 litre/m² using a

fine spray. When the site forms are removed within 24 hours and for small areas where a mechanical distributor cannot be used, the compound shall be sprayed by hand lance at the rate of 0.27 – 0.36 litre/m². The mechanical sprayer shall incorporate an efficient mechanical device for continuous agitation and mixing of the compound in its container during spraying. The curing time shall not include any period during which the temperature of the concrete falls below 0°C. The method of curing used shall prevent the loss of moisture from the concrete.

4.8.19 Finished Concrete Carriageway

At any transverse section of the carriageway the finished surface of the concrete shall not deviate from the design section by more than 3mm. The gap between the concrete surface and a three-metre straight edge laid longitudinally along the road shall not exceed 3mm.

Any high spots of less than 6mm shall be ground down. Where the gap exceeds 6mm the slab shall be removed and recast. Any areas removed shall not be less than 3m in length or less than the full width of the slab involved. Adjacent surfaces at any joint shall not have a gap of more than 3mm wide under a straight edge 750mm long laid across the joint.

4.8.20 Preparation and Sealing of Joints

Joints in concrete slabs shall be sealed using one of the hot applied sealants not less than seven days prior to the use of the road by traffic in accordance with type suitable for its location as specified in BS 2499 and Clause 1017, MCHW.

An appropriate primer shall be applied from a thermostatically controlled and indirectly heated dispenser with a recirculating pump.

The sealant shall not be heated to a temperature higher than the safe heating period both as specified by the manufacturer. The dispenser shall be cleaned out at the end of each day.

4.8.21 Statutory Undertakers Covers and Frames

Refer to paragraph 4.4.13

4.9 Block Paving

4.9.1 Concrete Blocks and Clay Pavers for Paving

Concrete blocks and clay pavers shall comply with the requirements of BS 7533. Concrete blocks shall be a minimum 80mm thick and clay pavers a minimum 65mm thick for use in carriageways, footways, footpaths and cycle tracks.

The skid resistance of concrete blocks shall be determined by the polished stone value (PSV) test and determined by the polished paver value (PPV) for clay pavers.

The minimum polished stone value (PSV) of any product shall be 55 unless specified otherwise.

4.9.2 Laying Pattern

Block surfacing shall be laid in a 45° or 90° herringbone pattern (as directed by the Project Engineer) with two stretcher courses adjacent to kerbs and a single stretcher course around ironwork unless directed otherwise by the Project Engineer.

4.9.3 Laying Course for Block Paving

The laying course material shall comply with the requirements of BS 7533 and detailed in MCHW, Volume 7, part 5 HD39/01.

The laying course shall be within $\pm 1\%$ of its optimum moisture content determined in accordance with test 12 of BS 1377. The laying course shall be such that after compaction it forms a uniform layer 30mm thick below the blocks.

The laying course shall be screeded to produce a uniform surface to correct design profiles and falls at a uniform degree of compaction.

4.9.4 Laying of the Block Paving

The blocks shall be laid hand tight in the design pattern, working from an existing laying face edge or edge restraint wherever possible. Mechanical force should not be used to obtain tight joints.

Block surfacing is designed to function with sand filled joints which will

normally lie in the range of 2 – 5mm when placed hand tight and may be influenced by block shape or laying pattern. The exclusion of mechanical tightening shall not be understood to preclude minor adjustments to maintain laying patterns. Full blocks shall be laid first; closure units should then be laid. The area to be laid shall be completed as far as possible in entire block units.

Wherever possible, infilling to boundaries and obstructions shall proceed as the laying of the surface course proceeds and in any case, infilling shall be completed before compaction commences.

In certain circumstances closure units are not suitable. Either dry packed sand – cement mortar or concrete (with a maximum aggregate size of 10mm) having a 28-day cube compressive strength of 40 N/mm² may be used as an alternative if approved by the Project Engineer.

Where it is not possible to fit blocks neatly around an obstruction, the obstruction shall be surrounded with concrete of similar colour and adequate strength to form a more regular shape. Blocks shall then be cut and neatly trimmed to abut the concrete collar using a diamond edge cutter.

The minimum size cut for a 200 x 100mm block shall be 50mm x 100mm (quarter block).

4.9.5 Compacting Block Paving

The surface course shall be compacted by use of appropriate equipment in order to ensure the filling of the lower portion of the block to block joint by the laying course material. Two or three passes of the compacting equipment will normally be required to achieve this condition.

Compaction shall follow block laying as soon as possible but shall not be carried out within one metre of the laying face.

Apart from this edge strip no area of paving shall be left uncompacted at the completion of the days' work.

4.9.6 Joint Filling

After compaction of the surface course, dry silver sand shall be spread over the surface and brushed into the joints.

The blocked surface shall then be vibrated as before in order to encourage the filling of the upper part of the block to block joint by the surface applied sand.

Top filling and final compaction shall be completed as soon as practicable after laying and in any case prior to the termination of work on that day.

4.9.7 Early Trafficking

Immediately after the finishing pass of the plate compactor, traffic may be permitted to use the pavement.

If, during the early trafficking period, any movement of the surface course occurs the units shall be removed, the cause established, and the area re-laid immediately.

4.10 Traffic Signs and Roadmarkings

4.10.1 Traffic Signs

All signs shall be approved traffic signs and manufactured from sheet aluminium to BS EN 485 with a minimum thickness of 11 swg or 3mm and complete with 76mm appropriate fixing clips. Circular signs over 600mm in diameter and triangular signs with a base width not exceeding 600mm must be stiffened and shall be capable of passing the tests described in BS 8442:2006.

All signs shall have retro-reflective surfaces complying with the requirements of BS EN 12899 - 1:2007 and reflectivity of signs to be in accordance with ECC policy.

As a rule of thumb waiting restriction signs are non-reflective (NR), direction signs are Class RA1 (formerly "Class 2") and all other signs are Class RA2 (formerly "Class 1").

4.10.2 Posts

Steel posts, with a minimum 76mm outside diameter, shall comply, where applicable, with the requirements of BS 4 and BS 4848 and shall be manufactured from steel complying with the requirements of BS EN 10025 - 1:2004 as detailed in BS 8442:2006 and galvanised in accordance with the requirements of BS EN ISO 1461 “Hot Dip Galvanised Coatings on fabricated Iron and Steel Articles”.

Each post shall have a base plate and cap to prevent the ingress of water in accordance with the requirements of BS 8442:2006. All clips, screws, bolts, nuts and washers that come into contact with the sign shall be of stainless steel.

4.10.3 Street Nameplates

No street nameplates shall be displayed in a new street until the street has been named by the Borough or District Council in accordance with appropriate statutory powers. Street nameplates and any supplementary plates considered necessary by the Borough or District Council shall be provided and erected by the Developer.

The nameplates shall satisfy the DfT Circular Roads 3/93 and shall be to the approval of the Borough or District Council. Prior to any property on the development being occupied all street nameplates shall be erected.

Whilst the street is under construction, temporary signs may be used, but permanent nameplates shall be fixed in position before the street works are complete. The Developer shall obtain any necessary agreement before a nameplate is erected on private land (outside the limits of the highway to be adopted) or attached to any private boundary of any property.

At cul-de-sac, street nameplates shall be a combination street nameplate and No Through Road sign as approved by the relevant Authority or as shown in Diagram 816.1 of the Traffic Signs Regulations and General Directions 2016, or any superseding legislation.

4.10.4 Fixing and Erection

The fixing and erection of street nameplates shall be to the satisfaction of the Borough or District Council.

4.10.5 Road Markings

Materials for road markings shall be selected from the following:

- Screed thermoplastic
- Sprayed thermoplastic

The above shall comply with the requirement of BS 3262 for “Superimposed Road Markings”. Statutory requirements controlling road marking are contained in the TSRGD 2016 and subsequent amending regulations. All road markings shall be in accordance with Clause 1212, MCHW.

4.10.6 Road Studs

Statutory requirements controlling reflecting road studs are contained in the TSRGD 2016 and subsequent amending regulations.

All reflecting road studs shall comply with BS EN1463 - 1 and Clause 1213, MCHW.

4.11 Street Furniture and Ancillary Items

4.11.1 Gates and Stiles

Stiles, bridle gates and kissing gates shall comply with BS 5709:2006 and Clause 304 and 311, MCHW. Concrete for post foundations shall comply with Clause 2602, MCHW. The location of the above shall be to the approval of the Project Engineer.

4.11.2 Salt Bins and Gradients of Road

Salt bins are to be provided for all roads that have more than 25 properties where the gradient is steeper than 5% and the distance of the proposed highway is a minimum of 50 metres.

The maximum gradient of 8% which is defined in the Essex Design Guide for road types E - H will only be allowed in exceptional circumstances and where the retention of the existing topography is a consideration. Steeper gradients will not be permitted.

The proposed salt bin should be positioned within land outside of the adoptable highway. Confirmation will be required that a Management

Company or local Parish/District/Borough Council will be responsible for its ongoing maintenance. The actual position of the salt bin should be carefully assessed before it is placed to ensure it is in the best place for the majority of people to use on a self-help basis.

Where there is no option but to have the bin positioned within the proposed adoptable highway a commuted sum will be required for both the bin and for the provision of the salt.

Essex County Council will restock the salt bin in preparation for the start of the winter season. Beyond this, we cannot confirm how often we will be able to refill the bins during the winter season as our resources must be prioritised to secure the precautionary network.

Should a site within the adoptable highway prove problematic because of regular misuse of salt for the treatment of private driveways, or vandalism of a bin, the Council reserves the right to remove the bin.

Each bin whether it is within private land or the adoptable highway will need to be photographed to verify its condition and location. It should also be noted who is responsible for its ongoing maintenance. This is so there is an up to date inventory of all salt bins in the County Council area.

A sticker is to be added to the bin to confirm that the salt is for the use on the public highway only.

4.11.3 Bollards

Bollards other than illuminated bollards shall be manufactured from either precast concrete, a synthetic material as approved by the Project Engineer or fabricated from metal. Concrete bollards shall comply with the manufacturer's specification and performance. Metal bollards shall be designed to withstand a vehicle impact and the finish shall be similar to that specified for lighting columns unless periodic maintenance will not be required. Specific approval of the type of bollard to be used shall be obtained from the Project Engineer.

4.11.4 Road Restraint Systems

The requirement to install a Vehicle Restraint system shall be guided by the

document '*Design and Maintenance Guidance for Local Authority Roads - Provision of Road Restraint Systems on Local Authority Roads*' published by the UK Roads Liaison Group in October 2011.

A Vehicle Restraint System shall conform to the *MCHW Volume 1 Series 400* and be designed in accordance with *TD19/06 'Requirement for Road Restraint Systems'*. For all sites that are 50mph or more and that exceed 5000 vehicles per day a *Road Restraint Risk Assessment Process (RRRAP)* will be required as part of a design submission. For those sites that do not meet the speed or traffic volume criteria a Site-Specific Risk Assessment will need to be submitted for the Engineers approval.

Vehicle Restraint Systems must comply with the relevant parts of *BS EN 1317 'Road Restraint Systems'*- a European Standard that identifies test methods and impact test acceptance criteria. As such, a design submission must be supported by Certificates of Conformity that show the CE marking. Additional supporting information from the manufacturer of a proprietary system should also be provided.

It is critical that the design of post foundations is proven ahead of a VRS system being installed and the method for testing is outlined in *BS 7669: Part 3 1994 'Guide to the Installation, Inspection and Repair of Safety Fences'* or it shall be carried out as defined by the manufacturer of a proprietary system.

A VRS Design submission should be forwarded to the Development Management Team as soon as reasonably practicable so that an evaluation of future maintenance costs - including parts procurement and training can be fully appraised. All identified concerns will need to be fully resolved before technical approval is granted.

On satisfactory installation of a Vehicle Restraint System a copy of the 'As Built' drawings including the General Layout and Engineering Details shall be submitted to Development Management Team. In addition, in accordance with *MCHW Clause 401 item 7* the Contractor shall provide for each proprietary system installed, a signed certificate certifying that it has been installed fully in accordance with the manufacturer's instructions. Any variation must be noted and approved.

4.11.5 Pedestrian Guardrail

Pedestrian Guardrail shall conform to *MCHW Volume 1 Clause 411* and shall be designed in accordance with *TD19/06 Chapter 9*. It shall also comply with *BS7818: 1995 'Specification for pedestrian restraint systems in metal'*. All steel used shall be galvanised in accordance with the requirements of *BS EN ISO 1461 'Hot Dip galvanized coatings on fabricated iron and steel articles'*.

4.12 Street Lighting

4.12.1 Preparation and Planning

All enquires must be directed via the Project Engineer at the initial design stage for forwarding to the Street Lighting Team. A unique file reference shall be allocated to the scheme which must be quoted on all future correspondence and scheme enquiries.

Prior to commencing a street lighting design, the Developer shall obtain a site-specific lighting brief from the ECC (via the Project Engineer). This will provide additional site-specific information to be used in conjunction with the Street Lighting Development Management Specification.

Note: *Street Lighting Designs must be in accordance with the ECC Street Lighting Development Management Specification. Designers should be thoughtful to use the minimum amount of street furniture with the least amount of energy consumption. The designer may be asked to provide separate calculations in order to prove this which may affect approval times.*

The Developer shall note the typical lead-in times to be allowed at Planning Stage.

- Lighting design and calculations to submit and commented upon by the Highway Authority – 3 weeks *Note. This will be considerably longer if the design requires amendments and resubmitting.*
- Delivery and installation of equipment – 8 to 12 weeks.

4.12.2 Street Lighting Specification

The Street Lighting Specification will provide the developer and designer with

the following information:

- Columns
- Erection of columns
- Luminaires
- Control gear
- Switch gear
- Fuse gear and fusing
- Cable networks
- Wiring
- Earthing
- Painting
- Service connections
- Inspection and testing

4.13 Soft Landscaping

4.13.1 Standard Landscaping – Grass Verges

Essex County Council will adopt grass verges as part of the public highway.

The grass and soil in the verges should be of an approved hardy variety that is slow growing. It should be of such a slow growing variety that only two grass cuts per year are required. A basic commuted sum will be charge for grass cutting of verge areas in accordance with Appendix E.

4.13.2 Enhanced Landscape - Trees and Shrubs

All other forms of landscaping are considered to be an “enhancement” thus will attract a commuted sum (see Appendix E). Any proposed planting within highway verges shall be in accordance with the details of the planning consent and must first be approved by the Project Engineer.

Trees and shrubs will be considered for adoption and will only be permitted to be planted in the highway on payment of an appropriate commuted sum (See Appendix E).

Planting in the highway will only be acceptable provided that all safety issues are satisfactorily addressed. This includes the following criteria: -

- New trees not to be planted within any visibility splays (including at junctions and bends).
- Any landscaping (planting, shrubs etc) within visibility splays should not be expected to grow more than 600mm in height above the adjacent carriageway level.
- Planting shall not obstruct access to underground services.
- Trees shall be sited clear of overhead service lines as required by the relevant Statutory Undertakers.

Provision to be made for suitable root boxes/barriers to protect services and the highway from movement and damage. Advice and information regarding the appropriate design of root barriers is provided in BS5837:2012: Trees in relation to design, demolition and construction.

Where highway verges were previously planted with bulbs, it will be expected that the new verge will be similarly planted, unless previously agreed with the Project Engineer.

Further information on plant species and root barriers can be obtained from the Tree Officer at ECC or refer to the Project Engineer.

4.13.3 Planting of Shrubs and Trees in Highway Verges

Topsoil shall be spread to a 300mm depth over all shrub areas. Trees shall be planted in a pit backfilled with a mixture of two parts topsoil to one-part peat free compost. Tree pits shall be 1000mm square by 600mm deep with the bottom of the pit broken up for a further depth of 150mm. Planting shall be carried out between November and February.

For further information regarding the design and construction of Tree Pits with associated root protection etc please discuss with the relevant Project Engineer. (Folio Drawings showing typical construction details will be available during 2016).

Shrubs shall be planted in pits of a size to accommodate the roots without restriction; the pit shall be backfilled with topsoil and peat free compost at a ratio of 4 to 1.

Before planting containerised tree stock two stakes shall be driven into the bottom of the pit until firm at 400mm apart. The finished height of the stakes shall be 400mm above ground level and a wooden cross bar attached. The tree shall be secured to the cross bar with approved ties.

For bare root standard tree nursery stock, a single stake is suitable.

In all cases soil should be properly firmed into the root system of the tree or shrub and the soil finished 20mm above the surrounding ground level. After planting, a mulch of bark or composted wood chippings 75mm thick shall be applied to the planted area. Planting shall be completed as early as possible.

4.13.4 Topsoil

Topsoil to be used in the works shall comply with the requirements of BS 3882. It shall be a fertile medium loam free from any perennial weeds, weed seeds, contamination, rubble, subsoil and stones bigger than 50mm and a maximum stone content of 20%.

4.13.5 Compost

Compost shall be a planting and mulching compost (peat free), bark or composted wood chippings.

4.13.6 Fertilisers

Areas where fertilisers shall be applied:

- Turfing – pre-seeding fertiliser (applied at a rate of 50g/m²)
- Tree pits – slow release tree fertiliser
- Trees/hedges/shrubs/bed planting – slow release fertiliser

All fertilisers shall be applied to the manufacturer's recommendations and rates. The Developer may add any additional plant nutrients which they consider the constitution of the soil warrant.

4.13.7 Turfing

All highway verges and margins including areas required for visibility shall be covered with a layer of topsoil (minimum 150mm deep) rolled and turfed

with cultivated weed free amenity turf. The turfs shall be laid with broken joints well butted up and rolled to regular contours.

Turfs shall be well bonded and laid diagonally on side slopes and if necessary wooden pegs shall be used for pegging turfs.

4.13.8 Seeding

Where approved by the Project Engineer, the turfing of verges may be omitted, and the prepared soil sown with seed. Seeding shall be carried out in accordance with BS 4428:1989 to a rate of spread to be approved by the Project Engineer (refer to Sections 4.59 and 4.62)

4.13.9 Grass Seed

Grass seed sowing shall be carried out during March/April or September. The grass seed mix below is a general-purpose mix which is suitable for most highway locations. It shall be a tested mixture from an approved source and certificates of purity and germination shall be provided. Unless otherwise agreed by the Project Engineer, the mixture shall consist of the following:

- 50% Esquire perennial ryegrass
- 35% Samanta slender creeping red fescue
- 10% Highland browntop bent
- 5% Rivendel white clover

However, some of these varieties may be specific to certain `seed houses` and alternative mixes may be presented by the Developer. This is acceptable providing the grass species remain at the same proportions.

4.13.10 Minimum Grass Verge and Planting Bed Sizes

Narrow grass strips between footways and carriageways and small isolated shrub beds are often neglected and over-run by vehicles. Where this occurs a form of hard paving is to be used. A minimum width of 1 metre and a minimum area of 10 square metres for grass and 1metre and 6 square metres for shrub and ground cover planting is normally acceptable.

4.13.11 Reinforcing Verges

Where it is necessary to reinforce verges to prevent erosion where vehicles are likely to be parked, including maintenance vehicles, you must use an approved system of reinforcement.

4.13.12 Tree Planting Within Paved Areas

Trees within hard paved areas should normally be planted within tree pits as per Clause 4.13.3 with the addition of tree grills and tree guards. For further information regarding the design and type of Tree Grills and Tree Guards please discuss with the relevant Project Engineer. Folio Drawings showing typical details will be available during 2016.

4.14 No Dig Policy

4.14.1 Construction Works Adjacent to Trees

Conventional road and footway construction within the Root Protection Area (RPA) of trees, employing excavation and backfilling of compactable load bearing sub base materials can seriously damage tree roots.

It is recognised that every situation is different, and any details of proposed highway works within the RPA will need approval of the Essex County Council Tree Officer – contact via Project Engineer.

The design of such works shall be carried out in accordance with BS5837:2012: Trees in relation to design, demolition and construction and NJUG Volume 4.

APPENDIX A - Tables

Table 1 – Industrial Adoptable Roads – Basic Data

Category	Design Speed	Minimum Widths		Bend Centre Line Radius		Minimum Forward Visibility
		C/way	Footway	Normal	Minimum	
Major Industrial Roads	50kph (30mph)	7.3m	Two x 2m	200m	90m	70m
Minor Industrial Roads	25kph (15mph)	7.3m Or 6.75m	Two x 2m	45m	20m	25m

Category	Minimum Distance between Centre Lines of Junction		Minimum Distance between Centre Line of First Junction and Commencement of Road	Normal Maximum Gradient
	Same Side	Opposite Side		
Major Industrial Roads	80m	40m	75m	6.00% (1 in 16.7)
Minor Industrial Roads	24m	10m	20m	6.00% (1 in 16.7)

Table 2 – Industrial Adoptable Roads – Widening on Bends

Centre Line Radius (m)	Widening (m)
20	0.60
30	0.40
40	0.35
50	0.25
60	0.20
80	0.15

Widening should be on both sides of the curve, or on the inside.

Note: *Where the road has been designed with two or more curves running consecutively or close to one another, any appropriate widening must be applied to the series of curves, reaching a maximum at the mid-point of the series. The degree of widening on such a series shall be based on the shortest radius.*

**Table 3 – Industrial Adoptable Roads – Construction Details (HD 26/06)
Pavement Design**

Layer	Material	Thickness of Layer (mm)
Surface Course	HRA 35/14F surf 40/60 rec, with 20mm pre-coated chippings, to comply with BS EN 13108-4, Hot Rolled Asphalt or 10mm HAPAS certified thin surface course compliant with Clause 942, MCHW and IAN 157/11	50mm 50mm
Binder Course	AC 20 HDM bin 40/60 rec, to BS EN 13108-1 Asphalt Concrete or HRA 60/20 bin 40/60 rec, to BS EN 13108-4 Hot Rolled Asphalt	60mm
Base	AC 32 HDM base 40/60 rec, to BS EN 13108-1 Asphalt Concrete	200mm
Sub-base	Type 1 granular sub base material to Clause 803, MCHW (For CBR values less than 15% an additional capping layer is required. Refer to Appendix A Table 5 for capping layer thickness)	200mm (minimum)

Note:

1. *Recycled materials may be used in accordance with BS EN 13108 (for guidance refer to PD 6691: 2007 and Clause 803, MCHW.*
2. *For Polished Stone Values (PSV), Aggregate Abrasion Values (AAV) and average texture depth requirement, refer to section 4.6.8*
3. *For notes on the use of reclaimed bituminous material refer to Table 5, note 12.*

Table 4 – Road Type Table

	Road Description	Max No Dwellings	Min Carriageway Width, Cycleway/Footway Requirements	Design Speed	Visibility Splays	Max Gradient	Min Centre Line Radius	Kerb Radii	Lighting requirements	Comments
A	Local Distributor	n/a	7.3m & 1 x 2m footway, 1 x 3.5m cycleway/footway. Buses to use full laybys. Pedestrian and cycle crossings to be provided on identified desire lines.	60kph 40mph	Junction and forward visibility splays will comply with current policy standards; please refer to DMRB or Manual for Street	5%	DMRB	10m for non-industrial, 15m for industrial	Lighting will be provided in accordance with ECC Street Lighting Development Management Specification	Multi-purpose through route, minimum 3 metre verges required. Classification of County route required. Clearway. To provide appropriate visibility at junctions a straight section of carriageway will be provided from the entrance junction for 30 metres.
B	Link Road	n/a	6.75m & 1 x 2m footway, 1 x 3.5m cycleway/footway. Buses to use half laybys or on carriageway. Pedestrian and cycle crossings to be provided on identified desire lines.	50kph 30mph	Junction and forward visibility splays will comply with current policy standards; please refer to DMRB or Manual for Street	5%	44m	10m	Lighting will be provided in accordance with ECC Street Lighting Development Management	Served by more than one access road. Links neighbourhoods and also serves non-residential or industrial uses. Minimum 3m verges required. No parking except where off carriageway provision is made. Public transport route. To provide appropriate visibility at junctions a straight section of carriageway will be provided from the entrance junction for 22 metres.
C	Mixed Use Street	n/a	6.75m carriageway comprising of two 3m running lanes with generally a 0.75m central over run-able strip & 2 x 2m footways. Bus route.	30kph 20mph	Junction and forward visibility splays will comply with current policy standards; please refer to DMRB or Manual for Street	5%	20m	10m on a bus route otherwise 6m	Lighting will be provided in accordance with ECC Street Lighting Development Management Specification	Serves residential and non-residential uses; for example, High Streets. On-street parking in bays. Street trees required. Details in The Urban Place Supplement. Over run-able strip should be wider where appropriate e.g. at crossing points. To provide appropriate visibility at junctions a straight section of carriageway will be provided from the entrance junction for 22 metres.
D	Feeder Road	n/a	6.75m if used as a bus route now or if this is expected in the future, or 6m. Both with 1x2m footway and 1x3.5m cycleway/footway.	30kph 20mph	Junction and forward visibility splays will comply with current policy standards; please refer to DMRB or Manual for Street	6% on a bus route otherwise 8%	20m	10m on a bus route otherwise 6m	Lighting will be provided in accordance with ECC Street Lighting Development Management Specification	Direct in or out of 30kph (20mph) area. May serve non-residential uses. Network must be permeable. No parking except where off carriageway provision is made. A 50kph (30 mph) speed limit may be considered on a public transport route where it is not possible to provide appropriate traffic calming for a 30kph (20mph) speed limit. To provide appropriate visibility at junctions a straight section of carriageway will be provided from the entrance junction for 22 metres.
E	Access Road	400 units on a loop, or 200 for a cul de sac	5.5m with 2 x 2m footways or 1 x 2m footway if fewer than 25 dwellings are served.	30kph 20mph	Junction and forward visibility splays will comply with current policy standards; please refer to DMRB or Manual for Street	8%	13.6m	6m	Lighting will be provided in accordance with ECC Street Lighting Development Management Specification	No access restrictions. Priority for cyclists. To provide appropriate visibility at junctions a straight section of carriageway will be provided from the entrance junction for 15 metres.

F	Minor Access	25 units in a cul de sac	Combined pedestrian/vehicle surface 6m. maximum length 125m for a cul-de-sac. Localised narrowing where appropriate'.	30kph 20mph	Junction and forward visibility splays will comply with current policy standards; please refer to DMRB or Manual for Street	8%	13.6m	4m	Street lighting not required.	Tabled entrance approach. Gateway feature may be necessary. Priority for cyclists. To fall to centre drainage channel. To provide appropriate visibility at junctions a straight section of carriageway will be provided from the entrance junction for 15 metres.
G	Mews Court	20 units	Combined pedestrian/vehicle surface 6m. Maximum length 50m (cul de sac). Localised narrowing where appropriate.	30kph 20mph	Junction and forward visibility splays will comply with current policy standards; please refer to DMRB or Manual for Street	8%	13.6m		Street lighting not required.	Special junction detail. Special surface finish. Priority for cyclists. A constricted entrance enclosed by buildings or walls to a minimum height of 1.8m for the first 8m back from the footway of the major road (except for the 1.5x1.5m pedestrian visibility splays). No doors, gates or other entrances may open on to the mews within this first 8m. No windows or doors should open outwards over the highway or overflow pipes, single storey eaves etc project over the net adoptable area of the mews court. Building overhangs, including porches and 'bridging' are not encouraged and specific permission will be required. To provide appropriate visibility at junctions a straight section of carriageway will be provided from the entrance junction for 15 metres.
H	Private Drive	5 units maximum	5.5m for first 6m tapering down to a lesser width. Desirable max length 18m, longer requires a turning head of size 5 and passing bays.		Junction and forward visibility splays will comply with current policy standards; please refer to Manual for Street	8%			Street lighting not required.	Where private drive joins a 30kph (20mph) network, width can be reduced. To provide appropriate visibility at junctions a straight section of carriageway will be provided from the entrance junction for 6 metres.

Note: Version as of April 2020 but please check Essex Design Guide for current version.

Table 5 –Summary of Pavement Construction for Adoptable Roads

Design Guide Rd Type	Carriage-way width	Compacted Thickness of Flexible Pavement Course			
		Surface Course (S/C)	Binder Course (B/C)	Base	Sub-Base
Types A, B, C & D	7.30m 6.75m & 6.00m	40mm of HRA 30/14 F surf 40/60 rec, with 20mm pre-coated chippings, to comply with BS EN 13108-4 Hot Rolled Asphalt (see notes) OR 40mm of 10mm HAPAS certified thin surface course, to comply with Clause 942, MCHW and IAN 157/11 (See notes).	60mm of AC 20 HDM bin 40/60 rec, to comply with BS EN 13108-1 Asphalt Concrete OR 60mm of HRA 60/20 bin 40/60 rec, to comply with BS EN 13108-4 Hot Rolled Asphalt.	200mm of AC 32 HDM base 40/60 rec, to comply with BS EN 13108-1 Asphalt Concrete (to be laid in two layers). OR 200mm of AC 32 dense base 40/60 rec, to BS EN 13108-1 Asphalt Concrete (to be laid in two layers).	200mm minimum of Type 1 granular material to comply with Clause 803, MCHW (For CBR values less than 15% an additional capping layer is required. Please refer to notes 6 & 8).

Design Guide Rd Type	Carriage-way width	Compacted Thickness of Flexible Pavement Course			
Types E, F & G	5.5m & 6.0m (including pedestrian margin and service strips)	40mm of HRA 30/14F surf 40/60 rec, with 20mm pre-coated chippings, to comply with BS EN 13108-4 Hot Rolled Asphalt (see notes) OR 40mm AC 10 Close SURF 100/150 to BS EN 13108-1 Asphalt Concrete (see notes) OR 40mm of HRA 55/10F surf 40/60 rec, to comply with BS EN 13108 Hot Rolled Asphalt (see notes)	60mm of AC 20 dense bin 40/60 rec, to comply with BS EN 13108-1 Asphalt Concrete OR 60mm HRA 60/20 bin 40/60 rec, to comply with BS EN 13108-4 Hot Rolled Asphalt	165mm of AC 32 dense base 40/60 rec, to comply with BS EN 13108 -1 Asphalt Concrete (to be laid in two layers) A sacrificial AC20 Binder course is to be used as a running surface for construction traffic for the duration of the build or until the formal Binder / Surface Course is ready to be laid (see Note 14)	200mm minimum of Type 1 granular material to comply with Clause 803, MCHW (For CBR values less than 15% an additional capping layer is required. Please refer to notes 6 & 8).
		OR 80mm thick concrete block paving to BS EN 1338	30mm sharp sand to BS EN12620	100mm of AC 32 dense base 40/60 overlaid with 65mm AC20 binder (see Note 14)	

<p>Footway or Cycle Track (adjacent carriageway) Independent Footpath or Independent Cycle Track</p>	<p>25mm of AC 6 dense surf 100/150 rec, to comply with BS EN 13108-1 Asphalt Concrete OR 30mm of HRA 15/10 F surf 100/150 des to comply with BS EN 13108-4 Hot Rolled Asphalt OR 80mm thick concrete block paving to BS EN 1338 laid on 30mm sharp sand bed to BS EN12620</p>	<p>100mm of AC 20 dense bin 100/150 rec, to comply with BS EN 13108-1 Asphalt Concrete</p>	<p>Base omitted subject to Project Engineering design assessment</p>	<p>150mm minimum of Type 1 granular material to comply with Clause 803, MCHW (For CBR values less than 5% Type 1 sub-base material to be increased to 225mm thick).</p>
--	---	--	--	---

Design Guide Rd Type	Carriage-way width	Compacted Thickness of Rigid Pavement Course			
Concrete Carriageway		For engineering details refer to the construction drawing as signed and approved by the Project Engineer			
Concrete Bus-bay	3.25m minimum	200mm thick concrete grade C32/40 air entrained with C503 mesh	0.125mm thick waterproof membrane to MCHW Clause 1007	150mm thick lean mix concrete to MCHW Clause 1030	150mm min. of Type 1 granular material to comply with Clause 803, MCHW (for CBR values less than 15% an additional capping layer is required. Please refer to notes 6 & 8).

Note:

1. All material in carriageways to be laid by machine.
2. All material to be in accordance with the MCHW, unless otherwise agreed.
3. Design Type Surface Courses may only be used in special cases with prior written approval of the Project Engineer.
4. Definitions:
AC = Asphalt Concrete
HRA = Hot Rolled Asphalt
SMA = Stone Mastic Asphalt CBR
= Californian Bearing Ratio
5. Minimum longitudinal fall in channels to be 1:170.
6. Minimum depth of non-frost susceptible material is 450mm for road pavements.
7. The minimum PSV and AAV for surface courses with and without pre-coated chippings, for adoptable roads is as described in paragraph 4.6.8 of this manual.

8. *To determine the required capping layer thickness to restore formation to 15% refer to CD225 Design for New Pavement Foundations.*
9. *Commercial/Industrial Adoptable Roads and Spine Roads should be designed in accordance with the Design Manual for Roads and Bridges.*
10. *The average texture depth for bituminous surfacing shall be equal to or more than 1mm and not more than 1.2mm.*
11. *For all bituminous materials, transportation, laying, compaction and type testing protocols shall conform to BS 594987:2010.*
12. *Where agreed in writing with the Highway Authority, reclaimed asphalt may be used in accordance with BS EN 13108 and Clauses 902 and 948, MCHW. For additional guidance refer to PD 6691: 2007.*
13. *Where the surface finish varies within the works e.g. asphalt, concrete, block pavers etc. the specification of materials used shall remain consistent throughout unless agreed otherwise by the Project Engineer.*
14. *Basecourse Material - The AC32 materials large stone content can result in it being open when laid and prone to fretting. Therefore, if the basecourse is to remain uncovered for any length of time an overlay of AC20 Binder Course is required*

Table 6 – Road Pavement Foundations

MPa	CBR	Class 2 Subbase Only		Class 2 Subbase on Capping			
		Material	Thickness (mm)	Capping		Subbase	
				Material	Thickness (mm)	Material	Thickness (mm)
30	2.5%	Not permitted		C1	430	SB1	250
35	3%	Not permitted		C1	380	SB1	230
40	4%	Not permitted		C1	330	SB1	220
50	5%	Not permitted		C1	250	SB1	200
55	6%	SB1	260	C1	240	SB1	190
60	7%	SB1	250	C1	230	SB1	170
65	8%	SB1	240	C1	220	SB1	160
70	9%	SB1	230	C1	210	SB1	150
75	10%	SB1	230	C1	200	SB1	150
80	11%	SB1	220	C1	190	SB1	150
85	12%	SB1	220	C1	180	SB1	150
90	13%	SB1	210	C1	170	SB1	150
95	14%	SB1	210	C1	160	SB1	150
100	15%	SB1	200	C1	150	SB1	150

SB1 = Type 1 inbound mixture to SHW clause 803

C1 = Capping to SHW clause 613

Note: A geotextile product to SHW clause 609 is required for subbase only option to separate subgrade and subbase layer.

Where the subgrade surface modulus is 50 MPa or lower, the foundation shall consist of subbase and capping.

NOTE 1 Foundations built on a subgrade surface modulus of 50 MPa or less have a relatively high risk of structural rutting during construction. This can be prevented through the use of a capping layer.

NOTE 2 Subbase only option is not permitted where the subgrade surface modulus is 50 MPa or less, which is a Local Authority variation of CD225.

Where the subgrade surface modulus is lower than 30 MPa, improvement of the subgrade shall be undertaken.

NOTE 1 Subgrades with a subgrade surface modulus value lower than 30 MPa are unsuitable to support the construction of a pavement foundation.

NOTE 2 Options for improvement of the subgrade include excavation and replacing between 500 to 1000 mm of the soft subgrade with granular fill, mechanical stabilisation (geogrids) and soil stabilisation. Options for improvement shall be discussed and agreed with the Local Authority.

Where the construction subgrade surface modulus is found to be lower than the design subgrade

surface modulus, then action shall be taken by either effecting improvement of the subgrade or by reviewing the design subgrade surface modulus with a view to redesign using the lower value.

The construction dimensions of the subbase layer & capping layer (if applicable) shall be based on the lowest value of subgrade surface modulus.

NOTE 1 The short-term subgrade surface modulus is an estimated value of stiffness modulus for the subgrade during construction.

NOTE 2 The long-term subgrade surface modulus is an estimated value of stiffness modulus for the subgrade when a state of equilibrium is reached under the pavement.

NOTE 3 The construction subgrade surface modulus is an estimated value of stiffness modulus of the subgrade measured during construction.

NOTE 4 The design subgrade surface modulus is an estimated value of stiffness modulus for the subgrade used for foundation design. It should be based on a geotechnical engineering interpretive site assessment. It is the lower of the short-term and long-term subgrade surface modulus.

Table 7 – Granular Bedding and Fill for Flexible Pipes and Land Drains

Percentage by mass passing		
BS sieve size	Type A (0/20)	Type B (20/40)
80mm		100
63mm	-	98-100
40mm	100	80-99
20mm	80-99	0-20
10mm	50-90	0-5
4mm	30-75	-
2mm	15-60	-
0.500mm	0-35	-
0.125mm	0-4	-
0.063mm	0-3	-

Note:

1. Type 'A' granular material for pipe bedding and pipe surround to Clause 503.3(i) MCHW and graded in accordance with Table 6 above.

Fill material (includes for land drains and temporary drains) shall consist of free draining, hard, clean, chemically stable gravel, crushed stone or crushed slag not greater than 40mm diameter and in accordance with Clause 505.2, MCHW.

2. Type 'B' selected filter material to Clause 505.3, MCHW and graded in accordance with Table 6 above shall consist of uniform, readily compactable materials free from tree roots, vegetable matter, building rubbish and frozen soil, and excluding clay lumps retained on a 75mm sieve and stones larger than 35mm.

Table 8 – Concrete for Ancillary Purposes to BS EN 206-1:2000 and BS 8500-1:2006

Purpose	Standard Concrete Type
1 Footings for fence posts and augered foundations for traffic sign posts	ST2
2 Foundations for safety fence posts, environmental barrier posts and planted lighting columns	ST5
3 Anchor blocks for safety fencing	ST5
4 Blinding concrete, backfill for structural foundations, over dig of post holes and preparation of formation to Clause 616, MCHW	ST1
5 Bedding and backing to precast concrete kerbs, channels, edgings and quadrants	ST4
6 Bed to drains Type A 1, foundations, channels and benching to chambers	ST2
7 Bed, haunch and surround to drains other than Type A (1), surround to chambers and gullies (1) <i>For Type A bedding and others refer to drawings F1 & F2, Volume 3, MCHW.</i>	

Note: *Certified proprietary concrete types may also be used, subject to the approval of the Project Engineer e.g. concrete for lamp column foundations by 'mix masters'.*

APPENDIX B

Figure 1 – Residential Adoptable Roads (5.5m wide) - Turning Spaces
 (All dimensions in metres)

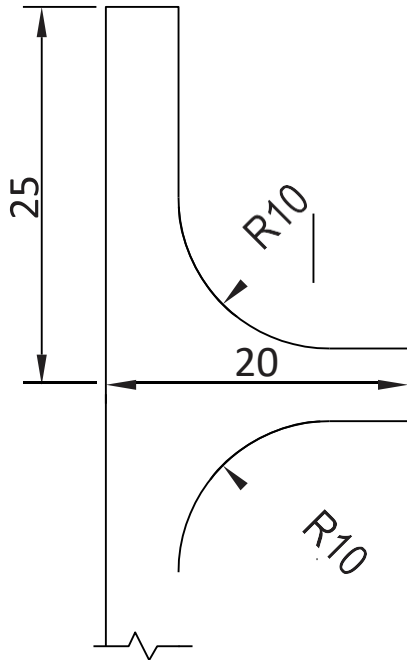

SIZE 1 Side Turn

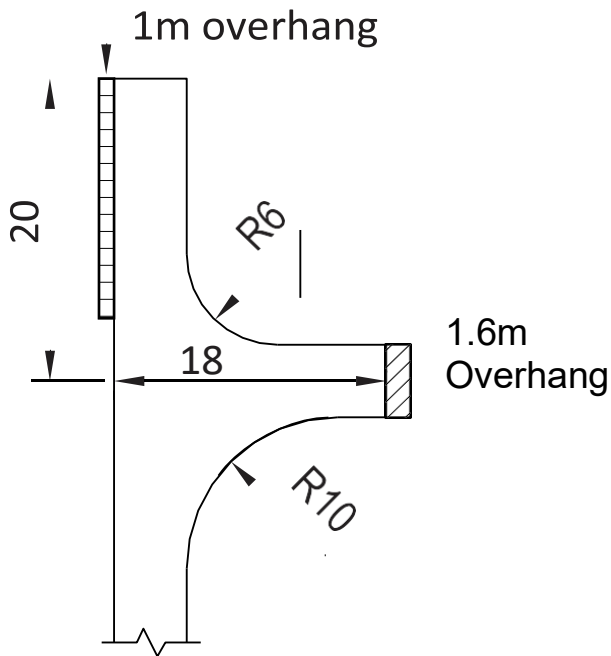

SIZE 2 Side Turn

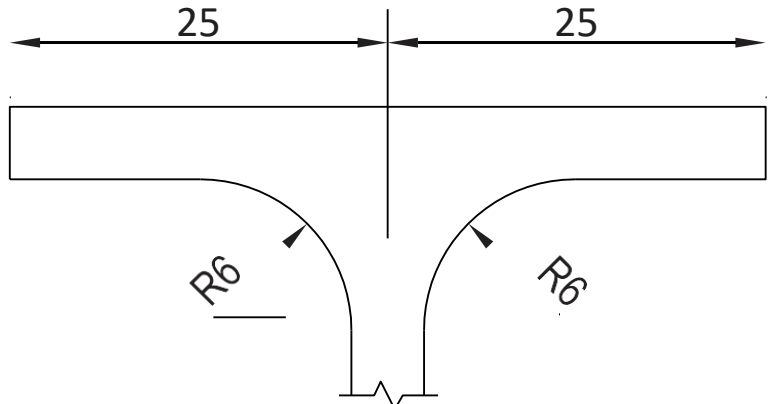

SIZE 1 'T' Turn

2m Overhang 2m Overhang

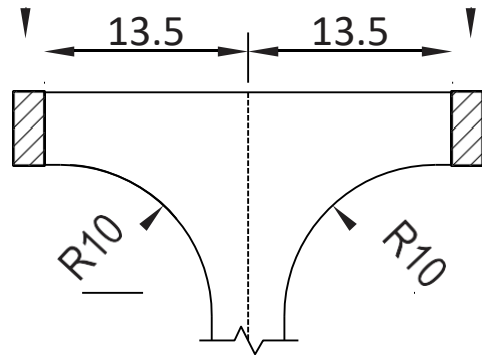

SIZE 2 'T' Turn

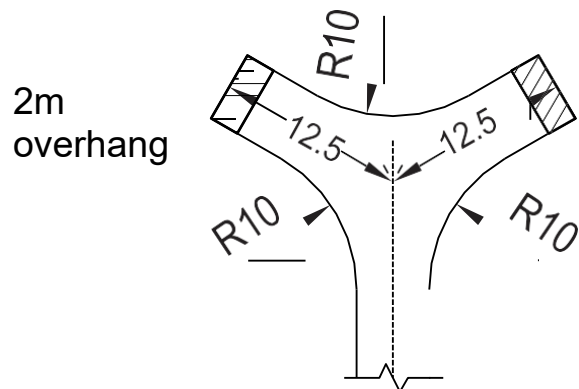

SIZE 2 'Y' Turn

Figure 2 – Residential Adoptable Roads (5.5m wide) - Turning Spaces

(All dimensions in metres)

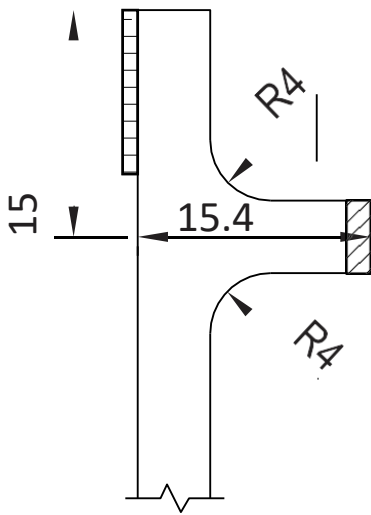

SIZE 3 Side Turn

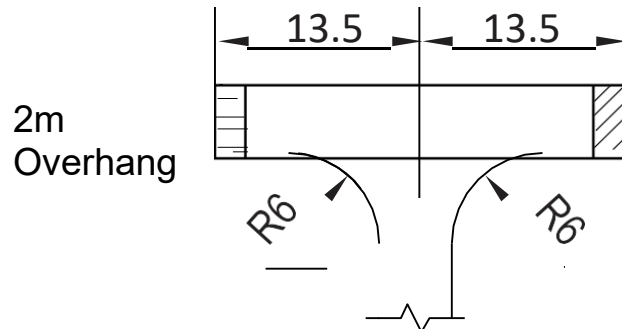

SIZE 3 'T' Turn

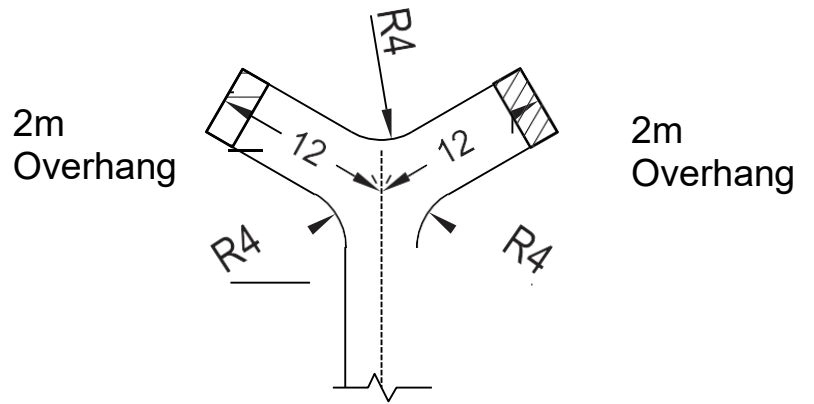

SIZE 3 'Y' Turn

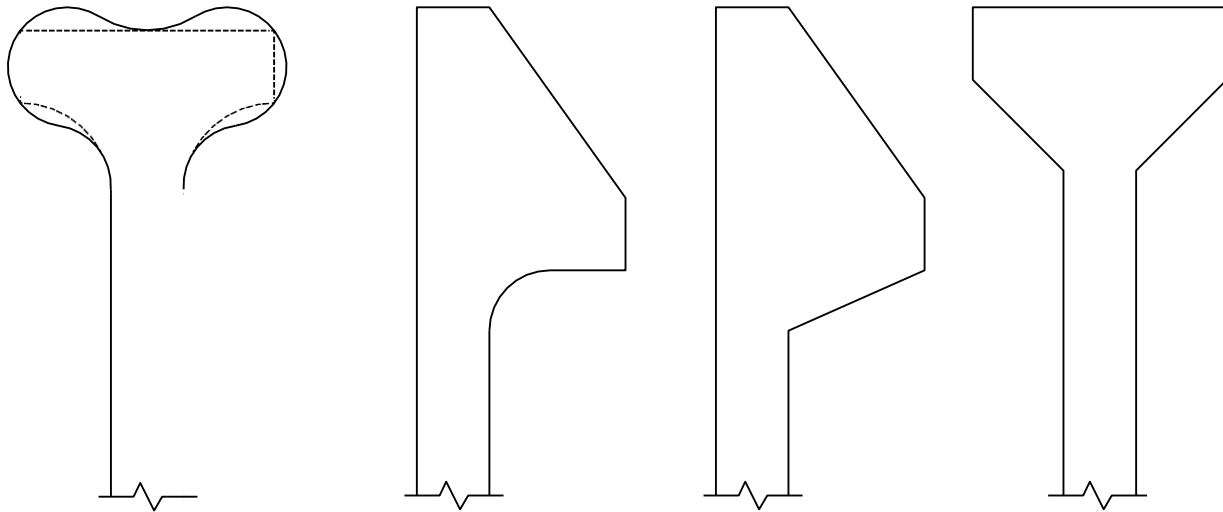

SIZE 3 Alternative Form

Figure 3 – Residential Adoptable Roads (5.5m wide)-Turning Spaces
(All dimensions in metres)

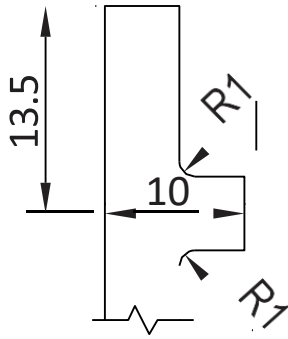

SIZE 4

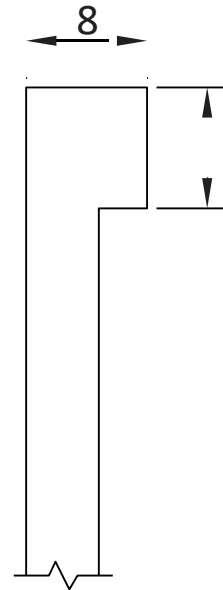
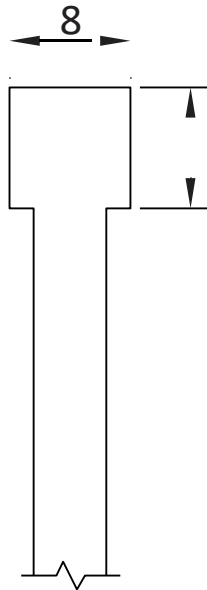
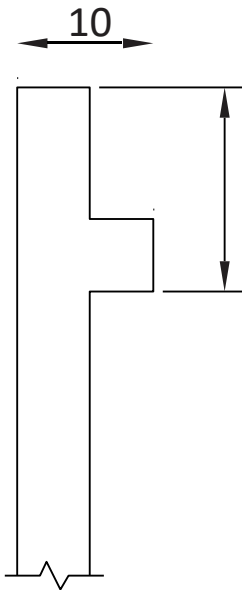

Size 5 Alternative Forms

Figure 4 – Industrial Adoptable Roads (6.75m wide) -Turning Spaces

(All dimensions in metres)

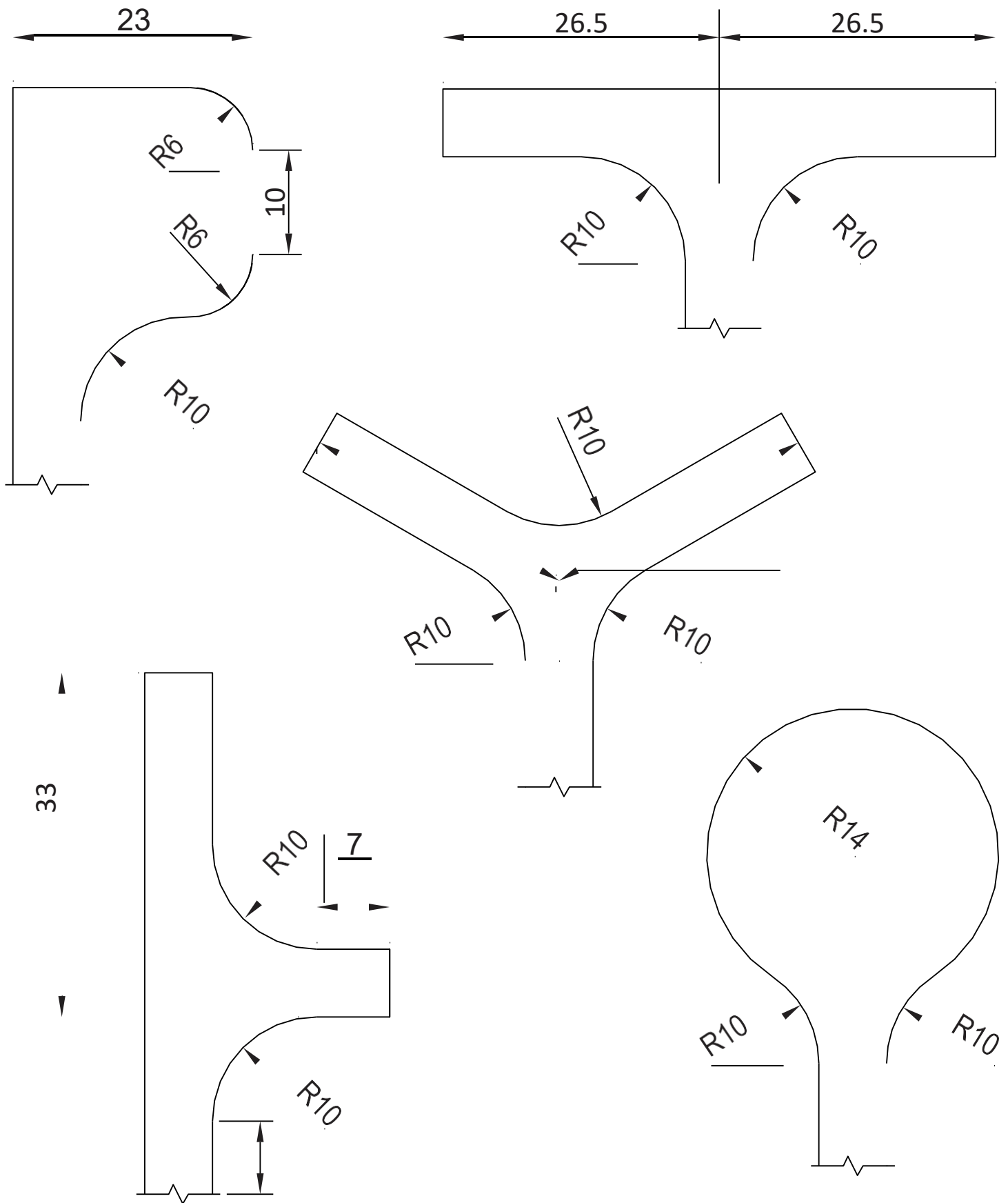

APPENDIX C – Notes for Guidance

Notes and information for guidance on the preparation and submission of project engineering drawings for new roads/residential schemes intending to be adopted by ECC under various agreements.

General

These notes are not exhaustive and in cases of doubt the Project Engineer should be consulted. The notes refer particularly to residential estates and although they are also generally applicable to industrial estates it is particularly important that the Project Engineer is consulted at an early stage when such adoptable roads are under consideration.

The drawings required in most cases are:

- Layout Plan
- Longitudinal sections of road and independent footways
- Longitudinal sections of surface water drains
- Typical cross sections of roads
- Constructional details

Additional drawings, including some detailed cross sections may be required by the Project Engineer.

All levels must be related to Ordnance Datum (Newlyn).

Layout Plan

Scale 1:200 or 1:500

Information to be shown:

- Layout of roads, footways and verges. Layout of sight lines.
- Layout of houses, garages, hardstandings and vehicle crossings. Layout of concrete bays and flexible bellmouths.
- Locations of gullies and lines of gully connections.
- Lines of surface water sewers and/or drains and locations of surface water manholes.
- Lines of foul sewers and locations of foul sewer manholes.

Layout of Carriageways, Footways and Verges

The layout of carriageways shall generally comply with the current Essex County Council's "Essex Design Guide", unless otherwise agreed by the Project Engineer.

The layout of roads, paths and verges shall be shown, and the information shown shall include centre line chainages, the widths of carriageways (including widening on bends where applicable), the widths of footways and verges, the tangent points and centres of curves, the radii of curves, the kerb radii at junctions, the dimensions of turning bays, of acceleration and deceleration splays, and of laybys and sight lines.

Chainages shall be shown at intervals of not more than 30 metres. High points and low points shall be marked.

The widths of the carriageways, footways and verges together with the sight line requirements shall comply with the widths determined and approved when the scheme was submitted for Planning Consent, or to the subsequent requirements of the Director for Commissioning, Transport and Infrastructure and shall include for widening on curves and clearly indicated on the plans.

If widening of carriageways on bends is required, details shall be made available.

Tangent points shall be marked on all kerb lines where there is a change of radius or where a curve meets a straight.

Where independent footpaths are proposed for adoption, full construction details are required including long sections, drainage, street lighting, barriers etc.

No windows or doors should open outwards, or overflow pipes etc. project over the adoptable area of the highway, or over other areas where the public have access. **This point should not be overlooked in the design process.**

***Note:** The opening of windows over the public highway has prevented adoption in a number of cases or has caused*

unnecessary problems resulting in windows altered to open inwards after residents have moved in.

In the case of cul-de-sac layouts, a turning space is required.

At the junctions of new adoptable roads with existing public roads acceleration and deceleration splays may be required.

Where the construction of a layby is required, the type of construction, position and dimensions shall be approved by the Project Engineer.

Details of road markings at junctions shall be required. See the TSRGD 2016 and any succeeding regulations.

Layout of Sight Lines

Sight lines shall be shown at all junctions and on such bends as the Project Engineer may require. The land in front of such lines shall form part of the adopted highway and the lines shall be defined on the site by lengths of footway edging set along the sight line at each property boundary, with not more than 10 metres between the edgings – *known as “hit and miss” edgings*. If fences or walls are to be erected, then the sight line can be defined by the front face of such fences or walls.

The following note should be marked on the drawing for each sight line:

- On open plan layouts where no walls or fences are provided, note to read, "Sight lines defined by line of footway edging, the land in front to form part of the highway".
- Where fences or walls are to be provided, note to read, "Sight lines with walls or fences erected thereon, the land in front to form part of the highway".

The sight line dimensions at junctions shall be decided by the Project Engineer in each case including vehicle/pedestrian sight splays at the junction of private drives with adoptable highways.

On curves and bends a minimum forward visibility shall be provided on the centre of the inside lane (normally taken as 1.5 metres from the inside kerb line), in accordance with Planning Approval.

Layout of Houses, Garages and Hardstandings

The layout of houses, garages and hardstandings is intimately related to the layout of the roads, footpaths and vehicle crossings and to the detailed positioning of gullies, carriageway expansion joints etc. It follows that no changes shall be made in the layout of houses, garages or hardstandings without the need for corresponding changes in the road layout and detailing being investigated and agreed with the Project Engineer.

The layout of houses, garages and hardstandings in respect of which planning consent has been given shall be shown on the plan so that the positions of the vehicle crossings can be determined. Hardstandings and driveways (which must be shown from the garages to the back of the footway) shall be so aligned that they meet the back of the footway at right angles. This condition may be relaxed within turning bays and the Project Engineer shall be consulted. The minimum size of a hardstanding is 5.5 metres x 2.5 metres per vehicle unless located in front of a garage where the length shall be increased to 6 metres to enable the garage doors to be opened while the hardstanding is in use.

The position of vehicle crossings of the footway shall be shown by parallel lines 0.914 metres apart at each end of the crossings to indicate the ramped sections of footway. Vehicle crossings should not cross radius kerbs at junctions or turning bays. Back to back ramped kerbs will not be permitted.

A minimum of 4 dropped kerb units i.e. 5.5 metres overall including ramps shall be provided for a single crossing (a maximum of 5 dropped kerb units is allowable) and a minimum of 8 dropped kerbs i.e. 9.1 metres overall for a double crossing.

In certain cases where a house has two garages (or a carport and a garage) it may be possible to provide only a single crossing. In developments of this type the Project Engineer shall be consulted.

Footways incorporating mountable kerbs should be a minimum of 2 metres in width.

Pram/wheelchair crossings are required at all junctions and other locations to be determined by the Project Engineer.

Layout of Concrete Bays and Flexible Bellmouths

The bay layout shall be designed using the County Council's current standard details for junctions and turning bays etc. and then dividing the distances between these into equal length bays, as near to 9 metres long as possible. No bay may exceed 11 metres in length, this dimension being measured on the outer kerb line of bends.

The layout of the concrete bays shall be shown on the plan and each bay is to be numbered. Expansion joints shall be shown by a dotted line and tied joints by a thin solid line.

A note shall be made on the plan of any bellmouth junctions with existing roads which are to be constructed in flexible materials. The setting out of such junctions shall be agreed with the Project Engineer and a note to this effect shall be added to the drawing.

The double row of granite setts at the junction between the concrete slab and the flexible bellmouth construction is to be indicated by a note.

Locations of Gullies and Lines of Gully Connections

Locations of gullies and the lines of gully connections shall be shown. Gullies are to be spaced so that no gully drains more than 200 square metres of carriageway and footway or in the case of shared surface streets 150 square metres. This means, for example, one pair of gullies every 42 metres on a 5.5 metres wide cambered carriageway with two 2-metre-wide footways and one gully every 18 metre on a 7.3-metre-wide crossfall carriageway with two 2-metre-wide footways.

Gullies shall be provided at the low point of vertical curves and 6m from the low point (on both sides).

Channel type gullies are required and ideally shall be situated adjacent to raised kerb.

Drawings shall show at least 0.914 metres of raised kerb between a gully and the nearest ramped kerb. In concrete carriageways gullies shall be situated adjacent on expansion joints or at least 2.2 metres from the nearest expansion joint.

Gully connections not exceeding 10 metres in length shall cross the carriageway as near to right angles to the centre line of the carriageway as possible. Pipe junctions shall not be situated under the carriageway.

At junctions with existing roads, existing gullies shall be shown.

Lines of Foul and Surface Water Drains, Sewers, and Manhole Locations

Where the surface water drainage system takes water from the adoptable roads, footways etc, and houses, parking areas and private areas, this shall be offered for adoption by the appropriate Water Authority.

Where the surface water drainage system takes water solely from the adoptable road, footways etc, this shall be offered for adoption, along with the road, by the Highway Authority and the necessary details submitted for approval.

Please see Appendix I for a standard Section 38 pro forma

The lines of foul and surface water drains and sewers and the locations of all manholes shall be shown on the plan. Foul and surface water drains and sewers should ideally be located under the footways, verges or gardens, and not in the roads. Pipes crossing the road shall do so as near to right angles as possible to the centre line of the carriageway.

Roof water drainage connections to surface water sewers shall be shown. If such drainage is to soakaways, then no portion of a soakaway shall lie within the highway boundaries.

Manholes ideally shall not be located in the carriageway. Each manhole must be numbered. The numbers of surface water manholes shall be prefixed with the letter "S" and the numbers of foul manholes by the letter "F".

Pipes and manholes to be adopted by the Highway Authority shall lie within the highway boundary. In the case of outfall pipes, when this is not possible, a deed of grant may be required.

A plan to a scale of at least 1:500 will be required of any off-site outfall surface water drains or sewers.

Surface water runoff from the roads is normally piped to a suitable ditch, river or surface water sewer. In exceptional circumstances soakaways will be considered and the Project Engineer should be consulted.

Rights to discharge surface water onto private areas. Any conveyance

relating to parking areas shall include a clause permitting the discharge of surface water drainage from independent footpaths (whether adopted or otherwise) onto parking areas.

Road Longitudinal Sections

Preferred Scales - Horizontal 1: 200, Vertical 1: 20

The sections shall show the existing ground as a dotted line, the proposed road channels as solid lines and the proposed road centre line as a broken line.

Information to be shown on the section:

- Centre line chainages
- Existing ground levels
- Proposed levels on centre line and channels
- Horizontal alignment on centre line and channels
- Vertical alignment
- Adjoining road widths

Additional details of levels and gradients may be required at bellmouths and turning heads.

Road Cross Sections

Preferred scales – 1:20

The sections shall show the existing ground as a dotted line, the proposed road profile as a solid line and the proposed road centre line as a broken line.

Information to be shown on the section:

- Centre line chainages
- Existing ground levels
- Proposed levels on centre line and channels
- Channel offset distances from centre line
- Typical cross sections of each width and type of road showing full constructional details of footways and carriageways shall be shown

Centre Line Chainages

Centre line chainage shall be related to that shown on the plans.

Existing Ground Levels

Existing ground levels shall be shown at least every 30 metres and at sudden changes of slope. Ground levels shall be extended for at least 30 metres beyond the end of every road.

Where a new road is an extension of an existing road the levels of the existing road shall be shown at 2.5 metres intervals for at least 30 metres.

Where the new road forms a junction with an existing road then existing channel levels shall be shown along the existing road at 2.5 metres centres, to a distance of 10 metre on either side of the tangent points. Levels of any existing gullies shall be shown.

Proposed Levels

Proposed levels on the centre line and the channels shall be shown every 10 metres on straight gradients, at all changes of gradient, every 5 metres on vertical curves and at each end of vertical curves. The intersection point level of vertical curves shall also be shown. Channel levels shall be shown at 5 metres intervals where there is transition between camber and crossfall.

Vertical Alignment

Proposed centre line and channel gradients shall be stated as a percentage as well as a fraction. Points of change of gradient shall be shown together with the lengths of vertical curves.

Vertical curves are required at gradient intersections and shall be designed in accordance with the following requirements:

The length in metres of a vertical curve is calculated as approximately 10 times the algebraic gradient difference. The length so calculated shall be rounded up for crest vertical curves. Vertical curves 10 metres or less will not be required.

The minimum permitted channel gradients are 0.67% (1 in 150) for

concrete construction, 0.80% (1 in 125) for flexible construction and 1% (1 in 100) for concrete block paving. Where the channel is formed of precast concrete blocks or where other suitable channel drainage kerbs are used, the gradient shall not be less than 0.67% (1 in 150) In exceptional circumstances flatter gradients will be permitted where it can be demonstrated that the road will drain adequately, allowing for normal surface course tolerance.

At road junctions the gradient of the side road at the point where it joins the channel of the main road shall not exceed 2.50% (1 in 40) for a distance of 10 metres from the channel of the main road.

The channel gradient shall be shown at all junctions to ensure that over the length of the 10-metre radius (approximate length is 16 metres) there is a channel gradient of at least 0.67% (1 in 150).

Horizontal Alignment

The points of commencement and termination of horizontal curves shall be shown, and the radius of the curves must be stated. Chainages shall be shown along the centreline of the new carriageway.

Transverse Profile

The lengths of camber, crossfall and changeover shall be shown.

On straight lengths the carriageway profile is to be cambered 2.5% (1 in 40). Crossfall may be required on certain bends, details of which need to be agreed with the Project Engineer. The changeover from camber to crossfall is normally to be on the straight section of road.

Channel gradients shall still be steeper than 0.67% (1 in 150).

Longitudinal Sections of Surface Water Drains and Sewers

Preferred Scales – Horizontal as plan, usually 1: 200, Vertical 1: 20

The sections shall show existing ground as a dotted line. Final finished surface level and the invert and soffit of the surface water drains and sewers shall be shown as solid lines. The sections shall also show manhole numbers, manhole positions, cover levels, invert levels, gradients, pipe sizes and the distance between manholes. The relevant

proposed finished surface levels with low points, gullies and road crossings shall also be shown.

Design details and calculations are required for any drainage proposals intended for adoption by the Highway Authority. This includes any soakaways if permitted.

Street Lighting

If street lighting is provided and installed, a lighting layout shall be prepared by the Developer (including lit bollards and signs) for approval by the Highway Authority. The preferred design method for this is the Lighting Reality software package.

Construction Details

Individual details are required for the following (if applicable):

- 1) Pram/wheelchair crossings
- 2) Gullies – carriageway and footway
- 3) Manholes
- 4) Ramps/rumble strips
- 5) Independent footpaths
- 6) Footway/footpath barriers
- 7) Soakaways
- 8) Headwalls
- 9) Expansion joints
- 10) Tied joints
- 11) Retaining wall details
- 12) Bridge details
- 13) Culvert details
- 14) Signalled crossing
- 15) Carriageway, footway and service strip construction
- 16) Road signs and lines
- 17) Kerbing
- 18) Verges
- 19) Pedestrian refuges and Traffic Islands
- 20) Laybys
- 21) Bus laybys

Together with details of any special items.

Submission of Project Engineering Drawings and Documents Required Prior to Commencement of Work

A copy of the outline, or combined outline and detailed planning consent and an exact copy of the accompanying plan, plus a copy of each subsequent formal approval of details and the accompanying plans.

Two complete sets of Project Engineering drawings (hard copies) and one electronic copy (uncoloured) comprising of layout, longitudinal sections and construction details. House positions should be indicated on the layout with plot numbers.

Preparation of Drawings for a Section 38/278 Agreement

Project Engineering Drawings:

Upon granting technical approval for Section 38 and Section 278 schemes, the approved Project Engineering drawings and specifications as stamped by the Project Engineer shall be issued accordingly.

- One set for the Developer
- One set for the Drawing File
- One set for the Clerk of Works

The colouring on one of the drawing sets should be as follows (the coloured plan)

Flexible Carriageway (inc Mews Courts and entrances)	Blue
Flexible Footways and Cycle Tracks	Brown
Grassed or planted areas	Green
Block paved areas (carriageway & footway)	Orange

This drawing is held by the Clerk of Works for the works.

Pink Plan:

For inclusion in the Section 38 agreement, **ten** copies of the pink plan are required. The pink plan should include the site boundary depicted in red and an inset location plan. If the land is in multiple ownership, then the second owner's boundary should be shown and shaded in blue. Separate location plans are no longer required.

Two copies of the plan should be retained by ECC, one for the file and one should be given to the Clerk of Works. The remaining eight copies of the pink plan are sent to Essex Legal Services.

Ensure that the colouring accurately ties in with any existing highway boundary (or previous Section 38 phase). The highway surface water system in respect of which the County Council will become responsible for maintenance including

- | | | |
|----------------------|---|-----------------------------|
| 1. Gullies | } | |
| 2. Manholes | } | |
| 3. Headwalls | } | should be shown in blue ink |
| 4. Gully connections | } | |
| 5. Drain lengths | } | |
| 6. Soakaways | } | |

If the Water Authority is to adopt the surface water sewers (roof water, private drainage, and highway water all draining into the same system) then these should be shown in **black** ink. Where sewers are highway drains (i.e. take carriageway and footway drainage only), then these should be coloured blue. The entire area coloured must be in the Developer's ownership.

Highway Drainage Easements should be shown on the pink plan coloured yellow.

Additional Information Required for Section 38 Agreement when Pink Plans etc are Submitted

Confirmation of the reference number and date of issue of the original planning permission and whether this was outline or a combined outline and detailed approval and the reference numbers and dates of all subsequent formal notices of approval details.

- The name and full registered address of the Developer.
 - The name and full address of solicitors acting for the Developer.
 - The name and branch address of the surety acting for the Developer
- Advice of any intention to install an oil pipeline system for the supply of heating fuel oil to the various properties.

Designers Checklist

The following table is a suggested checklist for assisting designers when considering the design of their schemes. The list is not exhaustive and should be used for guidance purposes only.

PRELIMINARY	
Highway Authority recommendations (planning consultations)	
Planning Consent Conditions	
Approved Planning Layout Drawing	
Public Rights of Way (PROW) affected	
Anglian Water Authority confirmation of intent to adopt	
Environment Agency Approval	
Copy of Flood Risk Assessment	
GENERAL	
Safety Audit	
Programme of Works	
Location of Highway Boundary	
Signing to comply with TSRGD	
20mph zone (over 100 meters)	
Waiting Restrictions	
Stopping Up Orders under S247 or S116	
Other Traffic Regulation Orders	
Section 177 Licences	
Retaining Walls Section 167 and AIP	
Section 50 Licence	
Wayleave / Easement Agreements (Utilities / highway drainage)	
Salt bins at steep gradients to be considered. In excess of 5% serving over 25 properties in a distance over 50m. Commuted Sum required for salt.	
LAYOUT	
Compliance with all planning consultation requirements/conditions	
Suitability of proposed road types & cycle routes – check widths	
Cycle/footway links – check connectivity with adjoining developments – Conversion order?	
Sight plays shown to comply with planning consent	
Forward visibility plays shown and dimensioned	
Junction sight lines	
Appropriate turning bays provided	
Route for refuse/emergency vehicles	

Distance from the junction that the road is to be straight (ensure 5m straights between bends)	
Footways to be located at rear of adoptable highway (include a verge between footway and kerb if necessary)	
Minimum curve radius (junctions and main line horizontally & vertically) – widen at bends if necessary	
Traffic calming features required by planning consent shown	
Flat top blister pattern used for pram crossings on Type 3 and higher category roads	
Appropriate bold note on drawing stating “No overhead projections, gas meter boxes etc to be sited over adoptable area or in adjacent areas open to be public”	
Demarcation for highway boundary	
Positioning of street name plates	
DRAINAGE	
Highway drainage system calculations (soakaways, any attenuation?)	
Trench backfill to be Type 1 under carriageway (6F1, 6F4, Class 1A or Class 1C accepted)	
Gullies serving max 200 square metres or in the case of shared surface streets 150 square metres	
Gullies at low points plus 6 metres either side and clear of pram crossings and vehicle crossings	
Gully connection not in excess of 10 metres.	
Highway catchpit construction and soakaways	
Gully size details conform to folio drawing	
Gully and manhole cover types and specification to conform with Section 4	
Piped ditch details. The minimum size normally permitted is 600mm dia. (EA approval needed if Main River or Watercourse or Water Regulation Team at Essex County Council for all other types of ditch/watercourse)	
Headwall details. Grills must be provided	
Drainage not permitted from private areas onto highway	
Unnecessary private drainage in adoptable highway	
Disclaimer for highway draining into private areas	
Highway longitudinal section minimum cover between pipe and formation is 600mm	
Concrete protection for drains less than 1.2 metres of cover	
Lockable grilles for culverts with fire service padlocks	
Minimum easement 3 metres both sides of pipe for all drains	
Compliance with soakaway requirements to BRE365	
Committed Sums required e.g. flow devices, landscaping, structures & enhanced electrical equipment	

VERTICAL ALIGNMENT	
Minimum gradient acceptable 0.80% 1 in 125 except for short lengths not exceeding 5m either side of a low or high point on a vertical curve where an average gradient of 0.67% is acceptable. 1.0% 1 in 100 min gradient for block paving. In exceptional circumstances flatter gradients will be permitted where it can be demonstrated that the road will drain adequately allowing for normal surface course tolerance.	
Change in grade at intersection of side roads	
Adverse camber at bellmouths eliminated	
Low points eliminated in channel of major road within bellmouths	
1% rate of change to gradient applied at transition from crossfall to camber	
DETAILS	
Soils report – CBR's and soakage tests	
Capping layer determined on CBR results	
Additional measures required for shrinkable clay, removal of trees or unstable ground	
Road types comply dimensionally	
Footway width – minimum 0.5m overhang strip provided where there is no footway	
Materials and pavement layer depths in compliance with Essex County Council specifications	
Layout pattern for modular block paving (45° herringbone preferred for trafficked areas)	
Tactiles in accordance with DfT guidance on the use of tactile surfaces for pedestrians and cyclists. Cycle tracks to be shared unsegregated unless conditioned otherwise. Individual crossing points to be shown.	
Kerb height and type	
Minimum 4/maximum 5 dropped kerbs plus ramped kerbs for a single vehicle crossing and minimum 7/maximum 8 plus ramped kerbs for a double	
Minimum 2 dropped kerbs for pram crossing with 0-6mm upstand	
Surfacing type and suitability – preference against surface dressing	
Traffic calming features – check which ones need advertising	
Road signs/mounting heights and location. Passively safe measures where required	
Sign face materials: <ul style="list-style-type: none"> • Class RA1 – Rural locations • Class RA2 – Urban locations 	
Safety/pedestrian barriers	
Passively safe posts/columns	

Deterrent paving construction	
Chicane construction	
Road marking details	
Bollard/railing size and type	
Trees – acceptable root barriers required – specify tree pits and species	
Fire service padlocks for secure access ways	
STREET LIGHTING DESIGN	
Design submitted and approved (MayRise details added to drawing)	
Column and luminaire types acceptable	
Commuted Sums secured if required	
Bold note to be made on drawing to read “Potential purchasers are to be advised of the location of street lights which are to be sited to avoid intrusion and glare into properties”	
Details of the cabling, feeder pillars and bollards. Service connection to be the Distribution Network Operator (DNO) supply cable unless otherwise approved. Details of IDNO if applicable	

APPENDIX D – Sampling and Testing Requirements for Adoptable Roads

- 1) All testing to be undertaken shall be at the expense of the Developer.
- 2) Testing of materials shall be by an independent UKAS accredited laboratory.

Testing requirements and frequency are as follows:

General

Sampling to be carried out by trained experienced persons to the requirements of the relevant British Standards.

Completed sampling certificates to be supplied with all samples and made available to the Project Engineer.

All bituminous material shall be temperature checked with appropriate thermometers on delivery, laying and rolling to comply with the relevant British Standard.

Materials complying with Clause 942, MCHW (thin surface course systems) shall be laid and tested in accordance with the said clause and Interim Advice Note 157/11.

Sampling rates as set out below are for routine testing only. Additional sampling may be required to the approval of the Project Engineer.

Adoptable Housing Estate Roads

a) Bituminous Material Analysis

Surface course	1 sample per 75 tonnes
Binder Course	1 sample per 100 tonnes
Base Course	1 sample per 100 tonnes

Pre-coated Chippings 1 sample per days delivery

A minimum of 2 samples (from different loads) per day per material being laid should be taken.

b) Other Bituminous Tests.

- Texture depth - to be tested daily during surface course laying.
- Rolling straight edge testing - to be tested daily during binder and surface course laying.

The compaction of base and binder course macadam shall be assessed by measurement of:

1. In-situ and refusal air void contents of cores subjected to the Percentage Refusal Density (PRD)

And

1. PRD test procedure carried out in accordance with the Clause 929, MCHW; and in-situ density using an indirect density gauge.

c) Other Material Tests

All materials shall be compliant with the appropriate requirements described in the MCHW.

Sub-base, capping, aggregates, pipe bedding etc. all materials tested for grading and moisture content at 1 sample per 200 tonnes per source with a minimum of 1 sample per day whilst being delivered.

Where recycled coarse aggregate or recycled concrete aggregate is used in unbound mixtures in accordance with Clauses 802 to 807 as appropriate, it shall have been tested in accordance with Clause 710. Other permitted material contents of recycled coarse aggregate and recycled concrete aggregate shall be determined in accordance with Clause 710 and shall comply with Table 8/3, MCHW.

d) Concrete

Concrete for ancillary purposes - testing is not normally required, however, if required Series 2600, MCHW shall be appropriate and a testing regime agreed with the Project Engineer.

Each load delivered to have 4 cubes made and tested for slump and where appropriate air content.

Pavement quality and Structural concrete shall be tested in accordance with series 1000 and 1700, MCHW.

e) Concrete Products

- 1 set of samples to comply with BS EN1339 for paving flags
- 1 set of samples to comply with BS EN1340 for kerb units
- 1 set of samples to comply with BS EN 1338 for paving blocks

Note: *Where clay or natural stone products are to be used they should be tested in accordance with the appropriate standards.*

Earthworks

Subject to the extent of earthworks, testing shall be carried out in accordance with an agreed earthworks method statement and testing regime which shall generally accord with Series 600, MCHW.

APPENDIX E - Payment of Costs

The following should be taken into consideration when works are being costed.

Works Cost

The full cost of the highway construction/alterations including structures, accommodation works, landscaping, drainage works, any alterations to plant required by statutory undertakers, alteration to traffic signing, street lighting, provision of traffic signals (if applicable), any temporary works, remedial/strengthening works to the existing highway.

Works Deposit

A bond or deposit to cover the entire cost for Essex County Council to complete the proposed highway works based on the approved drawing. The Project Engineer may decide in liaison with the developer to base the agreed figure on the cost of the tendered works including statutory undertaker's costs. If this is the case, full disclosure of the agreed tender price will be required. An additional small percentage will be added in addition to cover the cost of procuring the works.

Inspection Fee

The inspection fee is based on the cost of the works with a minimum charge of £1,795.52

Works cost between £50,000 and £500,000 – inspection fee is 8.5% of works cost.

Works cost between £500,000 and £1.5 Million – inspection fee is 7.5% of works cost.

Above £1.5 Million calculated on a scheme by scheme basis.

Staging of Inspection Fee payments

In order to cover our costs of reviewing drawings at the initial stages of the process, it is necessary to take an upfront payment until the full inspection fee is paid. This advance checking fee is generally **£3,000** but may be higher for a more complex scheme. This is taken for all schemes

until the works bond is calculated at which point **2.5%** of the total works cost will be charged for the drawing review i.e. part payment towards the 8.5% inspection fee the balance being payable before a Works Licence or Permit is granted. Or for a Section 38 Agreement when the Agreement is signed or if inspections are taking place before this. Any advance checking fee which has been paid can be deducted from this 2.5% payment. For small sites the fee will be calculated on a scheme by scheme basis. No drawing checks or inspections will be undertaken until the advance drawing checking fee is taken.

We reserve the right to request further monies if our costs are not covered due to an insufficient advance inspection fee. In particular, this is likely to be the case for structural and signals schemes. The remainder of the Inspection fee is payable on the issue of a works licence for Section 278/ work permit/ Section 228 schemes and on the signing of the legal agreement for Section 38 works or before if inspections are taking place. Inspection fees include costs for safety audits and specialist advice on traffic signals, structures and compensation issues. If the road works are still not complete after the time limit specified in the agreement, we will allow an extension of the works deposit for up to three years; however, we will reassess the bond value and charge you a further inspection fee based on our assessment of our increased costs due to the delay in adoption.

Traffic Regulation Orders (TRO)

A fee to cover the cost for producing and advertising related traffic orders. If the Highway Authority is required to install the signs and lines, an additional fee is required.

Type of Traffic Regulation Order	Fee
Standard Traffic Regulation Order (e.g. speed limit, weight limit, waiting restriction – including school keep clear markings etc.)	£2,841.38
20mph zone	£2,129.72
Temporary Road Closure	£1,526.86
Temp PRow Closure	£1,405.38

Section 228 Notice

A 228 notice incurs a cost of **£303.45** unless it is in lieu of an incomplete section 38 agreement. In this situation, the inspection fee applies and therefore an additional £303.45 is not required.

Proposed Commuted Sums (Also refer to Appendix L of “The Essex County Council Developers Guide to Infrastructure Contributions” – Revised Edition 2015)

A commuted sum to cover enhanced future maintenance for the highway works. These enhanced works are described as “extra-over” which is defined below. This will include but is not restricted to structures, traffic signals, non-standard drainage, non-standard street lighting, non-standard surfacing, grass cutting, verge planting and landscaping. In some circumstances where a development proposal is providing some betterment, it would be inappropriate to charge a commuted sum for maintenance; the circumstances where betterment will be considered is defined below. The figures below will be reviewed and updated in April of each year.

Extra Over

Section 38

The items which would be adopted without a commuted sum are the carriageway and adjacent footway for residential estate road (with standard flexible construction or 200 x 100 x 80mm concrete blocks), gullies, connecting pipes carrying highway drainage only and standard street lighting. All variations to the standard specification in these areas or additional areas will be subject to a commuted sum payment in accordance with the schedule of rates. Where a rate is not published for a particular asset these will be considered on a case by case basis with the aim of adding to the schedule of rates in the future.

Section 278

Generally commuted sums will be sought for any items listed in the Development Construction Manual Guidance. Commuted sums for any increase in hard surfacing in association with the reconfiguration of the public highway will be determined in accordance with the extra over rate for areas not required for highway purposes identified in the Development

Construction Manual i.e. they were not required for the existing highway to function but have been necessitated by the development proposal. Where a rate is not published for a particular asset these will be considered on a case by case basis with the aim of adding to the schedule of rates in future.

Betterment

Any proposal to reduce or eliminate a commuted sum for maintenance on the basis of betterment should be considered on a case by case basis. There should be a presumption that there will be no betterment discount unless the developer can provide a compelling case that:

- the commuted sum would undermine the viability of the development and the delivery of the infrastructure and associated public benefit
- the developer is providing an enhancement of an existing asset that was otherwise in need of maintenance in its existing condition
- the developer is providing mitigating infrastructure with wider public benefit that improves safety, capacity or integrated transport that is disproportionate to the impact of the development.

Standard Commuted Sums for Maintenance

Material or feature	Unit	Operation	Cost per cycle (£)
Extra-over Areas			
Extra-over areas not required for highway purposes (flexible construction)	m2	1 sweep per year. Resurface at year 15.	91.95
Extra-over areas not required for highway purposes (block paving construction)	m2	1 weedkill & sweep per year. Replace 1/3 blocks at year 15.	96.73
Roads			
Granite setts	m2	1 sweep per year. Replace granite setts at year 7 & 14	442.14
Non-standard blocks (tegular, clay pavements etc.)	m2	1 weedkill & sweep per year. Replace 1/3 blocks at year 15.	143.70
Coloured asphalt	m2	Resurface at year 15.	120.58
Non-standard surface dressing (HFS etc.)	m2	Reapply at year 7 & 14.	73.12
Drainage			
Swales		Site specific calculation. Contact Project Engineer	
Filter Drains / Infiltration Trenches	m	1 weedkill & clean per year. Replace stone every 5 year.	197.50

Other Sustainable Urban Drainage Systems (SUDS) or non-standard elements		Site specific calculation. Contact Project Engineer	
Hydrobrake	nr	Clean every 2 years. Replace at year 30.	4,664.55
Soakaway	nr	Clean every 2 years. Replace stone every 5 year. Replace at year 30.	8,745.04
Crate Soakaway	m2	Inspect and clean every 2 years. Rejuvenate at year 30.	495.81
Petrol & Oil Interceptors	nr	Inspect, clean, and dispose of contaminated waste every 2 years.	7,412.34
Combined kerb & drainage systems - 'beany blocks'	m	Enhanced cleansing regime required - once per year	378.08
Culverts	m	Clean every 5 years.	221.68
Street Lighting			
Non-standard Lanterns and/or painted columns		Site specific calculation. Contact Project Engineer	
Traffic signals and controlled crossings			
Zebra crossing		Site specific calculation. Contact Project Engineer	
Other signalised junctions & crossings		Site specific calculation. Contact Project Engineer	
Public transport			
Bus shelters		Site specific calculation. Contact Project Engineer	
RTI Display		Site specific calculation. Contact Project Engineer	
Bus gates, VMS, CCTV		Site specific calculation. Contact Project Engineer	
Structures			
Extra-over or enhancements upon standard structure. Includes bridge, culvert, tunnel, retaining wall, headwall, high mast or barrier, gantry, canopy, basement or water attenuation structure		Site specific calculation. Contact Project Engineer	
Signs and bollards			
Extra -over or enhancements upon standard sign	nr	Clean every 2 years. Replace at year 15.	1357.87
Extra -over or enhancements upon standard bollard	nr	Clean every 2 years. Replace at year 15.	504.29
Fencing and barriers			
Knee rail, or timber post & 3 rail fencing	m	Replace at year 15.	89.64
Noise attenuation barrier	m	Replace at year 15.	326.86
Vehicle restraining system (VRS)		Site specific calculation. Contact Project Engineer	
Trees and planting			
Tree in soft landscaping	nr	General maintenance	513.77
Tree with grills, pit or watering system, generally in hard landscaping	nr	General maintenance & 1 replacement of grills	761.12
Shrub/ground cover planting (Landscaping) or plantation screening	m2	General maintenance once per year	22.74

Hedges	m	General maintenance once per year	50.60
Grass verge	m2	Grass cutting 6 times per year	14.50
Street Furniture			
Enhanced cycle racks, street art if not licenced, etc.		Site specific calculation. Contact Project Engineer	
Grit Bins	nr	Supply of grit once per year. Replace at year 15.	1152.98
Miscellaneous			
Brickwork	m2	Replacement at year 15.	141.00
Continuous line in yellow single	m	Replacement at year 5, 10, and 15	6.95
Continuous line in yellow double	m	Replacement at year 5, 10, and 15	10.43

Legal Costs

A fee to cover Essex Legal Services work to process any legal agreements. This is not required for work permits. Essex Legal Services charge on an actual hourly rate so it is difficult to provide fees before works commence on any agreement/licence which involves their service. It should be noted that it is rare to allow any deviations from standard legal agreements and discussions on deviations significantly escalates costs.

Licences and Consents

All costs associated with obtaining consents, licences or provision required for the works and the procurement of any highway drainage easements or land requirements. The costs of the various licences and consents are as follows:

Type of Licence	Fee
Section 50 Licence	£994.69 for 5 year Licence and £1,094.69 for 25 year Licence
Section 72 Agreement	£715.28
Complex Section 72 Agreement	Calculated by Essex Legal Services- minimum of £850

S116 (removal of highway rights where public highway has been enclosed)	Around £4,000
Section 177 Licence	Around £600
Section 178 Licence	N/A
Section 247 Consultation (removal of highway rights)	N/A
Licence to Cultivate	N/A
Essex Unilateral undertaking for management Legal Services cost companies using Section 106 of the Town and Country Planning Act 1990 required to permit the Developer to keep the street private	£850 per UU Road
Drainage Easements – simple Deed of Grant	£292.11
Drainage Easements – those needed to be referred to our Property Consultants	£850

Application for Vehicle Crossing under Section 184

The cost of a simple application for a new or extended vehicle crossing is **£431.96 (includes £150 Permit and Stat fee)**

Application for Ordinary Watercourse Consent

The cost of a simple application for piping a ditch is **£50** per structure.

Land Purchase

The dedication as highway of all land which will form part of the new or improved highway, including visibility splays, if not already within highway boundaries, at no cost to Essex County Council. It is the responsibility of the Developer to undertake all dealings regarding any land acquisitions required for the work. The Developer must produce Title to any land to be transferred. If any Essex County Council owned land (other than land forming part of the Highway) is required for the works, then the Developer shall be responsible for all costs arising from (including the value of) Essex County Council providing such land.

Testing of Materials

The cost of the testing of materials on behalf of the Highway Authority will be borne by the developer.

Payment Details

BACS Payments

Bank: Lloyds Bank Plc

Address: City Office
PO Box 72
Bailey Drive
Gillingham Business Park
Gillingham, Kent
ME8 0LS

Sort Code: 30-00-02

Account No: 00508549

Account Name: ECC Revenue A/C

VAT REG NO: GB1042528 13

Please quote the DM reference provided in the initial instruction letter.

Please ensure we are aware your payment has been made, failure to do so will delay the payment being allocated or being identified.

Please send remittance advices, quoting the reference you have been given to the Banking Control & Reconciliation Team at BCRTeam@essex.gov.uk also copying in DM.Finance@essexhighways.org

APPENDIX F- PASSENGER TRANSPORT

Passenger Transport Infrastructure Standards Guide – Abridged Version

(For a full guide including information on major transport interchanges and appropriate Service Provision please contact the Passenger Infrastructure Team of Essex County Council)

This Guide aims to establish the County Council's commitment to; and the basic minimum design parameters to be applied to; all Road Passenger Transport Infrastructure across the County for all bodies involved in major and minor construction projects and developments.

The County has developed a range of standards for passenger transport infrastructure, based on best practice. These standards are based on the following overall concepts:

- That the County Council accepts in principle that it has a duty

to provide and maintain high quality public passenger transport infrastructure in association with its partners and constituent authorities and that installation should be agreed with operators, relevant authorities and residents.

- That this infrastructure should, as far as practicable, be accessible for use by all users.
- That the operational needs of infrastructure sites will vary and that realistically the standards for installing infrastructure at each site should be flexible enough to reflect this through a 'Stop Hierarchy'
- That, where practicable, priority measures should be incorporated in all new developments and transportation schemes to help maintain schedule reliability and provide a positive incentive to use public transport.

It is expected that these standards will be adopted into Supplementary Planning Guidance by the relevant Planning Authorities.

Note: *In the planning of all relevant new developments or other schemes involving roads the requirements for passenger transport infrastructure must form an integral element of the design. Schemes that do not do so will not be regarded as meeting the requirements of the LTP and where necessary the County will recommend refusal of planning permission.*

The Stop Hierarchy

A stop hierarchy has been developed to reflect the different requirements at different stop sites. It excludes stops at major interchange sites, which are considered separately:

- Rural Stops – stops in country areas outside villages; less well used stops in villages, or those only served infrequently (defined as less than one journey per week day)
- Village or Local Stops – principal stops in villages which have a regular service (defined as one or more journeys per day); stops in urban areas served by three or fewer journeys per week day
- Town Stops – The majority of stops in urban areas (defined as being served by more than three journeys per week day)

- Key Stops – stops served by more than three journeys per week day and where two or more services connect, or stops forming part of an interchange site

Bus Stop Infrastructure Standards

General Standards

This section contains the general principles and technical standards to which bus stops should be built. All stops should wherever practicable, be:

- Situated adjacent to a footway or hard standing on which passengers can safely wait clear of the carriageway
- Marked with a bus stop sign
- Protected by a bus stop clearway to prohibit stopping, waiting or loading of other vehicles at relevant times, to permit assured kerbside access, especially for accessible low floor buses
- Designed so that no pole, sign, shelter or other object is sited with any part of it nearer than 500 mm to the edge of the carriageway

Power Supply:

- Lighting will be supplied inside all shelters;
- Connected to an existing power supply (but not directly fed from street lighting columns), or;
- Connected via sustainable methods, such as Solar Power, where a current power supply is not available.
- Movement activated to avoid wasted energy consumption and must use LED's for maximum energy efficiency.
- Capable of illuminating the whole shelter, including timetable information
- Compliant with electrical safety standard BS7671 (as amended or updated), for which a Electrical Installation Certificate is supplied to Essex County Council on the day of being made live, via email.
- All electrical equipment installed must be a minimum of standard IP65

The use of bus boarders (build out) and lay-bys should be considered in the following circumstances:

- Where stop space is limited
- Where passenger transport has the highest traffic priority
- Where the road width allows for two-way traffic flow with kerbside parking

Lay-bys

- At places where buses habitually wait (e.g. termini)
- At locations on roads where permitted traffic speeds exceed 30 mph and/ or they are required by road safety considerations

Additional specifications, dependent on the category of stop outlined above, are detailed in the Table D1 below. Note that these apply to all stops, including existing stops, and do not override the design standards for new infrastructure where those are more stringent.

Table D1 – Bus Stop Standards

Feature	Rural stops	Village stops	Town stops	Key stops
Signage Mounted on a galvanised or similar pole, not telegraph pole or lamp standard or on integral mast on shelter Bottom edge of signs to be minimum of 2.5m from the ground level	Stop sign including location name Traveline and service numbers	Stop sign including location name Traveline and service numbers	Stop sign including location name Traveline and service numbers and AVL (real time information) repeater on all QBP or QBC routes and / or where thought appropriate	Stop sign including location name Traveline and service numbers and AVL (real time information)
Waiting area of hard standing or paved footway – minimum dimensions To be of paved or 'Tarmac' construction and visible to bus drivers at least 120m from the stop	2m long plus approach ramps 750 mm wide	5m long plus approach ramps 900 mm wide	12m long plus approach ramps 1.2m wide where possible	24m long plus approach ramps where possible 1.8m wide where possible 1.2m minimum

Height above road of kerb and waiting area	160 mm	160 mm	160 mm	160 mm
Space available for stationary bus(es) – minimum (dependent on suitability of stop site – engineering discretion may be applied)	12m length	18m length	18m length	32m x 4m
Road markings	Bus box* optional; bus stop clearway if essential	Bus box*; bus stop clearway if essential	Bus box*; bus stop clearway	Bus box*; bus stop clearway
Provision of shelter Any shelter should wherever practical conform with DDA standards, being constructed and laid out in such a way as to be	Where justified by usage and / or exposed location	Where justified by usage	Normally required where site permits	Required – size appropriate to usual demand; internal lighting
Provision of seating	Optional, required where shelter	Required in all shelters – optional elsewhere	Required in all shelters – recommended elsewhere	Required
Timetable information (also see Public Transport Information Standards) Timetable case to be a minimum of 650 x 220 mm and containing details of all services making use of the stop	Required	Required	Required at all boarding stops AVL (real time information) where part of QBP / C or if appropriate	Required – also route maps, and AVL (real time information)
All signs, shelters, seats, information cases and notices to be inspected and cleaned by the responsible body (see text) – maximum interval	Every 6 months	Quarterly	Monthly	Every 14 days
Additional facilities	Lighting (especially where there are shelters)	Lighting Litter bin Public telephone	Physical measures to assure kerbside access; lighting; litter bin, public telephone – optional	Lighting; public telephone; litter bin; pedestrian signing to stops; CCTV coverage, 'I Kiosk / Journey Planners'
Additional facilities to be considered	Cycle parking	Cycle parking; situate close to local facilities incl. telephone	Cycle parking; situate close to local facilities incl. telephone	Potential for Cycle parking / hire at stop

Infrastructure Specification

Planning should assume vehicle dimensions of 12 metres long by 2.55 metres wide. It may however be advisable to allow for articulated vehicles up to 18.75 metres in length.

In rural situations and conservation areas, shelters should fit in with the local surroundings, using appropriate design and materials.

Buses must be able to stop parallel to the kerb and given a 45 metres obstruction free run-in where this is possible.

There must be sufficient space allowed to let the bus enter and leave the stop safely while any adjacent stand is occupied.

A Passenger Shelter should be provided

- Adjacent to the bus loading point.
- Accessing onto the raised kerb section.

The shelter should be:

- An enclosed or semi-enclosed (three-sided) design.
- Allow a clear view into and from the interior.
- Fitted with glazed panels along the 'leading' end of the shelter (i.e. the end from which vehicles approach). No more than two unglazed or advertisement panels should be used.
- Set back from the kerb allowing enough room for access by wheelchairs or buggies.
- Provided with all-round protection from the weather and spray
- Provided with good internal illumination, which may be achievable by use of translucent.
- Roof panels where there is street lighting, or internal lighting
- Arranged so that the passenger queue faces approaching buses.
- Contain fixed seats for at least four people, mounted 440 - 480 mm above level ground and divided by armrests raised by 200 mm.
- Contain an information display case, repeating the information in the bus stop case, and a local map set at a height suitable for wheelchair users to read.
- Capable of being fitted with real-time passenger information displays

Where bus waiting areas or passenger shelters are in landscaped areas, there should be a clear paved or grassed area of at least 3 metres width. Where this is not possible, no shrubs or bushes within 3 metres should

exceed 750 mm in height.

Real Time Passenger Information

Will be supported along QBP routes and at other key sites.

Passenger Transport Priority Measures

Priority measures must be considered as part of any large-scale development. Measures can include:

- Bus only or passenger transport only lanes running beside conventional roads (with-flow or contra-flow). This may include stretches of guided Busways.
- Dedicated busways or passenger transport-only roads.
- Bus gates
- Bus or passenger transport advance areas at traffic signals.
- Bus or passenger transport only manoeuvres permitted at junctions (e.g. a right turn).
- Traffic signal priority by selective vehicle detection.

Measures should wherever possible be designed so as improve the transport network serving the site as a whole.

Bus Turning Facilities

Where bus turning facilities are provided, these must provide for a minimum external radius of 12.5 metres and should be in the form of:

- A roundabout, with associated lay-by(s) for waiting
- A dedicated turning circle, with passing facilities as necessary
- A bus station
- A short terminal loop

Turning points must be situated to allow relevant buses to serve all appropriate areas of the development without unnecessary diversion.

Maintenance and upkeep during development.

For the purposes of this strategy it is possible to divide maintenance into two categories – Upkeep and Repair.

‘Upkeep’ is the term applied to the small-scale maintenance work that needs to be carried out on a reasonably frequent basis. This includes such items

as:

- Regular sweeping, cleaning shelter and hard standing
- Emptying waste bins
- Litter picking
- Removal of minor graffiti
- Trimming of associated greensward or encroaching vegetation
- Undertaking minor repairs such as individual wind loosened slates
- Notification of major damage to the relevant authority

Repair

‘Repair’ is the term applied to all large-scale maintenance work required as a consequence of natural infrastructure ageing or vandalism. It includes:

- Total replacement of structure due to catastrophic damage or wear and tear
- Repair of damage to glass work, lights, superstructure or roofing material
- Repair or replacement of telematics equipment
- Replacement of damaged poles, kerbs ramps or other minor infrastructure

The developer will be responsible for the upkeep and repair while the development is ongoing.

Service Access to Developments

Bus service routes through developments.

Passenger Transport routes through development sites should:

- Be designed for through route operation avoiding ‘cul-de-sac’ operations, where services return along the same road.
- Link appropriately to the bus network outside the site, without requiring buses to by-pass other important traffic objectives
- Offer access for all areas, with a maximum distance between any unit and a bus stop of 400 metres (less if significant gradients involved).
- Allow stops to be sited close to the entrances of all key buildings
- Provide routes that will not be adversely affected by other traffic in the site; e.g. queues for car parks, manoeuvring delivery vehicles, or illegal waiting by cars picking up goods or people (especially at

- work finishing times)
- Provide priority measures for Passenger Transport over other traffic, both within the site and at access / egress points, to give quicker journeys than other traffic.
 - Provide turning and waiting facilities with sufficient capacity to accommodate relevant services

Width of Roads on Bus Routes

Roads expected to be used by buses should be built with a standard lane width of 3.375 metres.

Access for Smaller Developments

For some smaller developments where all parts of a site are already within 400 metres of an existing bus route, buses will not be required to enter the site. However, all areas of the site should have a clearly marked foot route to suitable waiting and boarding facilities.

Temporarily Suspending a Bus Stop

For information for parties wishing to temporarily suspend a bus stop please see attached information sheet.

Information Sheet for Parties Wishing to Temporarily Suspend a Bus Stop

A Party wishing to temporarily suspend any bus stop or other bus related infrastructure is required to provide the following information:

1. Full geographic details of the site, including the unique identification number (known as the Naptan ID) of any bus stops affected. Bus stop Naptan ID's may be found by reference to the Essex County Council bus stop internet database <https://ebusstop.co.uk/> (see guidance on the use of the database below).
2. A plan showing the proposed traffic management layout.
3. The proposed date, duration and times of the suspension.
4. The name and telephone of the manager who will be responsible for the site (this number must be contactable for the full time that the traffic management is in place).

This information must be supplied in writing to the email address below, giving at least 10 working days' notice wherever possible. Any changes to the information (e.g. changes to the completion date) must be advised immediately they are known.

IPTU.Infrastructure@essex.gov.uk

When suspending a bus stop, the Party doing so is required to:

- Cover the permanent bus stop sign and mark the stop "Bus Stop Suspended".
- Establish a temporary bus stop in a safe location as close as possible to the permanent stop.
- Erect a temporary bus stop which can be as simple as an A board with the wording "Bus Stop" written.
- Post information at the permanent bus stop location directing people to the temporary stop and letting passengers know how long these arrangements will be in place.

On the completion of work, the temporary bus stop sign must be removed, and the permanent sign uncovered or reinstated.

****Note:*** *In the unlikely event that no safe alternative location can be identified, notices must be put up prior to the bus stop being shut informing passengers of the location of the nearest bus stop.*

Guidance on using the bus stop database

On entering the database at <https://ebustop.co.uk>

- Click on “Stops by Location”
- Find the stop on the map
- Hover the cursor at the top of the blue balloon immediately above the stop so that you have a flat open hand symbol and left click once (this puts the coordinates in the search box next to the ebusstop logo)
- Click on submit next to the ebusstop search box

The relevant bus stop details will appear on the left of the screen: the NAPTAN ID is the top line titled “ATCO code” and starts with 1500.

APPENDIX G - MAINTAINABILITY AUDITS

Requirements

In order to limit the Highway Authority's future maintenance liability for materials, construction etc., new adoptable roads should meet the following requirements:

1. All adoptable areas should be accessible, easy to maintain and in all cases comply with the Construction (Design and Management) Regulations 2015.
2. Materials and products should be durable, safe, and appropriate for the purpose and comply with the relevant specifications and British Standard(s). Consideration must be given to the whole life cost of both the products being used and their design/installation.
3. Where possible, materials should be locally sourced, recyclable and sustainable in their production and use.
4. Where special materials or products with shorter life expectancies are used, or high-maintenance designs are utilised that will necessitate increased levels of maintenance (e.g. enhanced lighting columns/lanterns, soakaways, trees and landscaping etc.), appropriate commuted sum payments will be required by the Highway Authority to cover the additional costs of such future maintenance. (see Appendix E)

Designers Maintenance Checklist

The following table is a suggested checklist for assisting designers when considering the maintainability of their schemes. The list is not exhaustive and should be used for guidance purposes only when carrying out a full maintenance audit of the design and materials proposed in the delivery of the scheme.

CONSIDERATION	COMMENT
Scope & Scale	
Is there compatibility with existing infrastructure? – rural/urban conservation area, extension to existing development.	
What is the expected traffic use? – through route, bus route, commercial/HGV use, deliveries, emergency access, extraordinary traffic such as combine harvesters, nearby boatyard.	

Is the scheme a “unique”, high profile, prestigious project? Special design and material requirements, planning conditions	
Design Aspects	
Does the design allow for all areas that are being adopted easy access for maintenance?	
Are footways, verges etc. likely to be overridden by HGV's, refuse vehicles or other heavy vehicles. Is the area likely to have vehicles parked on it? – modify design, widen, and reinforce construction.	
Are grassed/planted areas of a size and position to be effectively maintained?	
Have trees/planting been selected and positioned to avoid future problems with roots, obstruction, leaf-fall, street light interference?	
Do traffic signs need to be illuminated or can they be reflectorized?	
What additional assets will be installed (i.e. number of gullies, signs, bollards, fences/barriers, bus stops/shelters etc)? Are they required - try to minimise street furniture wherever possible.	
Are design features sustainable? – e.g. sustainable urban drainage systems (SUDS)	
Does the design meet the requirements of the Equality Act 2010 (EA)	
Materials & Products	
What is the expected design life of the materials/products? Evidence should be provided based on available technical data and experience.	
Are materials of standard or specialist nature? – British and European Standards, or proprietary products operating under HAPAS schemes, durable, safe, fit for purpose, specification compliant.	
Are materials/products manufactured from recycled material? recyclable? Locally sourced, with replacement available? sustainable? e.g. permeable paving.	
Are more economical, easily maintainable alternatives available which could be used instead?	
Can materials be lifted and satisfactorily re-laid if required?	
Maintenance Operations	
Does the scheme (or any element of it) require specialist maintenance /cleansing regime or equipment?	
Will maintenance require special traffic management?	
Can maintenance physically be carried out in accordance with health and safety requirements? (inc. CDM regulations)	
Is there sufficient safe and convenient access available for maintenance plant and personnel?	

APPENDIX H – CONTACT LIST

Essex County Council	
Planning Stages	
(including the preparation of 106 agreements and 278 agreements)	
	Head of Economic Growth and Development Essex County Council Environment, Sustainability & Highways County Hall Chelmsford Essex CM1 1QH Tel: 08457 430430 Email address: transport.development@essex.gov.uk
	Relevant Office (see below)
Implementation Stage	
(including Advance Payment Code, the preparation of 38 legal agreement, processing of 278 agreements and minor works authorisations)	
Service Management Office (1) <i>Responsible for:</i> Braintree Colchester Tendring	Development Management Essex Highways Ardleigh Depot Harwich Road Ardleigh, Colchester, Essex CO7 7LT Email address: development.management@essexhighways.org
Service Management Office (2) <i>Responsible for:</i> Chelmsford Maldon Rochford Uttlesford	Development Management Essex Highways Springfield Depot Colchester Road Chelmsford Essex CM2 5PU Email address: development.management@essexhighways.org

<p>Service Management Office (3) <i>Responsible for:</i> Basildon Brentwood Castle Point Epping Forest Harlow</p>	<p>Development Management Essex Highways Childerditch Depot Unit 36 Childerditch Industrial Estate Brentwood Essex CM13 3HD</p> <p>Email address: development.management@essexhighways.org</p>
--	--

(4) References in this Agreement to the Owner shall include reference to the Owner's respective successors in title and assigns and to persons claiming through or under the Owner

(5) The Owner has secured to the Council's satisfaction sums of money under the advance payments code in the Highways Act 1980 in respect of plans of buildings proposed to be erected on the Road or Roads and having a frontage thereon in accordance with section 219 of the said Act and the Council is willing to exercise its powers under sub-section (3) of section 221 of the said Act and release the said sums so secured from the Owner and release it from its liability in relation to the said sums as shall be provided in this agreement

(6) The Owner has deposited with the Council under the advance payments code in the Highways Act 1980 a sum or sums of money in respect of plans of buildings proposed to be erected on the Road or Roads and having a frontage thereon in accordance with section 219 of the said act and the Council is willing to exercise its powers under sub-section (3) of section 221 of the said act and refund the same sum or sums so deposited to the Owner as shall be provided in this agreement

(7) Nothing in this agreement shall be interpreted as a consent to any structure over sailing the Road or Roads which is required under sections 177 or 178 of the Highways Act 1980 or any other enactment

(8) Nothing in this agreement shall be interpreted as a consent to any works under the Road or Roads which is required under section 50 of the New Roads and Street Works Act 1991 or any other enactment

NOW in pursuance of Section 38 of the Highways Act 1980 Section 111 of the Local Government Act 1972 and Section 33 of the Local Government (Miscellaneous Provisions) Act 1982 IT IS HEREBY AGREED AND DECLARED by and between the parties hereto as follows:

1. Interpretation:

IN this Agreement where the context so admits:

the "Drawings" means the Drawings listed in 1.1 of Schedule 1 annexed hereto and the Section Drawings listed in 1.2 of Schedule 1 and signed by or on behalf of the parties hereto and any amended such Drawing signed by or on behalf of the Engineer

the "Estimated Cost" is the sum specified in 1.3 of Schedule 1 being the amount which is in the opinion of the Engineer the cost of carrying out the Works within the period specified in clause 2(1) hereof

the "Final Certificate" means the certificate to be issued on satisfactory completion of the Works in accordance with clause 11 hereof

the "Maintenance Period" means the period specified in 1.4 of Schedule 1 hereof

the "Part 1 Certificate" means the certificate which may be issued on satisfactory completion of the Part 1 Works in accordance with clause 7 hereof

the “Part 1 Works” means the Works referred to in Part 1 of Schedule 2 hereto

the “Part 2 Certificate” means the certificate to be issued on satisfactory completion of the Part 2 Works in accordance with clause 9 hereof

the “Part 2 Works” means the Works referred to in Part 2 of Schedule 2 hereto

the “Engineer” means the Director for Commissioning Transport and Infrastructure of the Council or such suitably qualified person as he may from time to time nominate

the “Road or Roads” means the carriageways and footways of the Road or Roads hereinbefore referred to including any off-site highway drainage shown in blue on the Drawings and includes the footpaths street lighting all verges service strips service margins vehicular crossings road surface water drainage system (if any) and all other things ancillary thereto

the “Specification” means the edition of the publication entitled “Essex County Council Development Construction Manual” in force on the date of this Agreement a copy of which the Owner hereby acknowledges has been supplied to him or has downloaded from the Councils website

an “Undertaker” means an “undertaker” as defined in Sections 48(4) and (5) and 89(4) of the New Roads and Street Works Act 1991

the “Works” means the work specified in the Schedule hereto for the making up of the Road or Roads

the “Commuted Sum” means the sum specified in 1.6 of Schedule 1 to be utilised by the Council for the future maintenance of the features as specified in 1.7 of Schedule 1 as shown on the Commuted Sum Drawing specified in 1.8 of Schedule 1

the “Traffic Management Measures” means the construction of such traffic calming works including special paving overrun areas and chicanes together with such other traffic calming measures signs bollards road markings and other features as are deemed necessary by the Engineer following the Speed Survey to implement the 20mph Zone on the Road or Roads

The “20mph Zone Orders Sum” is the sum specified in 1.5 of Schedule 1 and means the Owner has paid to the Council arising out of the provision of traffic regulation or other legal orders and the implementation of such statutory or other procedures in relation to the 20mph Zone should the results of the Speed Survey require a 20mph Zone be applied to the site

the “Speed Survey” means a survey of the average speed of traffic using the Road or Roads to be undertaken as described in clause (26)

the “20mph Zone” means a speed limit restriction of 20 miles per hour which shall be applied to the Road or Roads along with any Traffic Management Measures if so required following the Speed Survey (subject to such consultation required by Part VI of the Road Traffic Regulations Act 1984 as amended and Part III of Schedule 9 to that Act)

the “Parking Restrictions” mean those parking restrictions as shown on the plan specified in

1.9 of Schedule 1 as agreed as being required by the Engineer and the Owner and following the results of consultations on such required by Part IV of the Road Traffic Regulation Act 1984 as amended and Parts III and IV of Schedule 9 to that Act

the "Greenfield Cost" is the sum specified in 1.11 of Schedule 1 being the amount which is in the opinion of the Engineer the cost of carrying out all Works required on the site

"Oversailings Structure" means any building or part of a building, pipe, wire, cable or other item

"Apparatus" has the same meaning as in Section 50 New Roads and Street Works Act 1991 and any amendment to the same by judicial interpretation of guidance issued by or on HM Governments behalf

The "Parking Restrictions Sum" is the sum specified in 1.10 of Schedule 1 which the owner is obliged to pay to the Council under clause 27

2. Owners Liability:

(1) THE Owner shall carry out and complete the Works at the Owner's expense in a good and workmanlike manner and with proper materials in accordance in all respects with the Specification and the Drawings to the satisfaction of the Engineer within the number of calendar months specified in 1.12 of Schedule 1

(2) THE Part 1 Works shall be completed within the number of calendar months specified in 1.13 of Schedule 1 from the date hereof and the Part 2 Works shall be completed within the number of calendar months specified in 1.14 of Schedule 1 of the date of issue of the Part 1 Certificate

(3) THE Owner shall as requested by the Engineer make all necessary arrangements for the testing of materials used in connection with the carrying out and completion of the Works to be undertaken by an independent accredited testing facility and the Owner shall bear the full cost of such testing and provide the Council with copies of all material testing certificates

(4) The Owner agrees not to install any oversailing structures which would cross or otherwise be within the airspace of the Road or Roads after the date hereof without a consent under sections 177 or 178 of the Highways Act 1980 or any other relevant enactment

(5) The Owner agrees not to install any apparatus under the Road or Roads after the date hereof without a consent under section 50 of the Street Works Act 1991 or any other relevant enactment

3. Declaration:

THE Owner hereby declares and warrants to the Council that he has and will throughout the duration of this Agreement maintain full right liberty and consent to carry out such works as may be necessary to connect the Road or Roads to a vehicular highway or highways

4. Essex Permit Scheme under TMA 2004

In so far as the County Council is as Highway Authority required by any legislation, Direction or Code of Practice (including in particular but without prejudice to the generality of the foregoing the Traffic Management Act 2004) to serve a notice or notices in respect of the Highway Works on Undertakers or other persons the Owner shall be responsible for complying with such requirement on behalf of the County Council and shall thereafter assume on behalf of the County Council such responsibilities as follow on therefrom

5. Indemnity:

- (a) THE Owner hereby indemnifies the Council in respect of all actions claims demands expenses and proceedings arising out of or in connection with or incidental to the carrying out of the Works other than those arising out of or in consequence of any act neglect default or liability of the Council
- (b) To hold the Council harmless and indemnified from all proper claims acceptance of offers charges costs and expenses made or incurred under or arising from Part IV of the Land Compensation Act 1961 Parts I and II of the Land Compensation Act 1973 and the Noise Insulation Regulations 1975 (SI 1975/1763) as amended by the Noise Insulation (Amendment) Regulations 1988 (SI 1988/2000) and the Owner shall make payment to the Council for such claims acceptance of offers charges costs and expenses within 21 days of receipt of a request to do so made in writing by the Engineer

6. Access to the Site:

THE Owner shall during the carrying out of the Works give to the Engineer and any other officer of the Council access to every part of the Works and sites thereof for the purpose of inspecting the Works and all materials used or intended to be used therein

7. Part 1 Certificate:

ON the completion of the Part 1 Works to the satisfaction of the Engineer in all respects the Engineer shall issue his Part 1 Certificate to the Owner and the bond will be reduced accordingly to the Part 1 costs

8. Occupation of Buildings:

NO dwelling erected by the Owner or on his behalf fronting adjoining or abutting on to the Road or Roads shall be occupied until:

- (a) the Engineer has issued his Part 1 Certificate in respect of the Road or Roads or such part of the Road or Roads as will provide the occupier with access to a vehicular highway and where applicable a base course pedestrian access to such highway has been provided and
- (b) the Road or Roads or such part of the Road or Roads have columns erected ready for lighting in accordance with the Specification and the Drawings and the Owner has arranged with the electricity company for an electricity supply thereto by giving at least six weeks' prior notice in writing or as may be otherwise agreed in writing by the Engineer

9. Part 2 Certificate:

ON completion of the Part 2 Works to the satisfaction of the Engineer in all respects and if any sewer constructed under the Road or Roads has been certified as being or having been on maintenance under an agreement under Section 104 of the Water Industry Act 1991 or if other suitable arrangements are in place for the adoption and or vesting of the sewers by or in the sewerage authority which is not to be adopted under the provisions of the Water Industry Act 1991 but has the benefit of a licence under Section 50 of the New Roads & Street Works Act 1991 in respect of the retention and maintenance of the said sewer [if SWL is required] the Engineer shall issue his Part 2 Certificate to the Owner and from the date thereof:

- (a) the Maintenance Period as specified in 1.4 of Schedule 1 shall commence to run
- (b) the Road or Roads shall become a highway or highways and remain forever open for use by the public at large

- (c) the Owner shall remain the street manager for the purposes of Part III of the New Roads and Street Works Act 1991 and any statutory modification or re-enactment thereof until such time as the Road or Roads shall become a highway or highways maintainable at the public expense
- (d) the bond will be reduced accordingly to the Part 2 costs
- (e) the Owner has carried out any Traffic Management Measures and Parking Restrictions as required under clause 27
- (f) the Owner has delivered to the Engineer drawings showing the Works as constructed including two complete sets of as-built drawings by email for the whole of the Works such drawings to be to such scale or scales as the Engineer may reasonably require for the purpose of subsequent maintenance and further works
- (g) the Owner has provided to the Engineer a correctly maintained Health and Safety File conforming in all respects with the Construction (Design and Management) Regulations 2015

10. Obligations During the Maintenance Period:

DURING the Maintenance Period:

- (a) the Owner at his own expense shall maintain the Works including all grassed and planted areas and carry out such routine maintenance as may be necessary to facilitate use by vehicles and pedestrians
- (b) the Council at its own expense shall undertake scheduled maintenance of and be responsible for payment for energy for all street lights and illuminated traffic signs
- (c) subject to the results of the Speed Survey the Council shall require the Owner to implement the Traffic Management Measures
- (d) subject to the results of any consultation in relation to the Parking Restrictions the Council shall require the Owner to implement works to give effect to the Parking Restrictions

11. CDM 2016 and Principal Designer

The DEVELOPER/OWNER is responsible for appointing a Principal Designer in respect of the Highway Works as required by the Construction (Design and Management) Regulations 2016 and before requesting a Final Certificate the DEVELOPER/OWNER shall provide to the Engineer a correctly maintained Health and Safety File conforming in all respects with the Construction (Design and Management) Regulations 2016

12. Final Certificate:

PRIOR to the expiration of the Maintenance Period the Owner shall forthwith at his own expense reinstate and make good any defect or damage which may have arisen from any cause whatsoever or be discovered during the Maintenance Period (including any defect in or damage to the road surface water system) of which he has been notified in writing by the Engineer so that the Works comply with the Specification

AND THEN PROVIDED THAT:-

- (a) the Owner has paid to the Council all amounts [including the Commuted Sum] due to the Council under this Agreement and
- (b) any necessary reinstatement or other Works have been completed to the satisfaction in all respects of the Engineer and

the Engineer shall issue his Final Certificate to the Owner and shall release the Surety from all liability hereunder

13. Grants of Rights of Drainage:

BEFORE the issue of his Final Certificate by the Engineer the Owner shall without cost to the Council execute or procure the execution by all necessary parties of such deeds as are in the opinion of the Council necessary to secure to the Council full drainage rights in respect of such parts of the surface water drainage system of the Road or Roads as are situate outside the limits of the Road or Roads and the Council shall not be liable for the payment of compensation or legal or any other costs or fees arising on account of the execution of any such deeds

14. Procedure for Inspection and Issue of Certificates:

(1) WITHIN twenty-eight days of receipt of written application from the Owner for the issue of a Part 1 Certificate a Part 2 Certificate or Final Certificate pursuant to this Agreement the Engineer shall inspect the Works and where necessary provide the Owner with a definitive list in writing of any remedial Works required to be carried out before the issue of that certificate

(2) Any such remedial Works shall be subject to the same inspection procedure detailed herein until such time as they shall be completed to the reasonable satisfaction of the Engineer who within twenty-eight days thereafter shall issue the relevant certificate

15. Adoption:

UPON the issue of the Final Certificate the Road or Roads shall become a highway or highways maintainable at the public expense

16. Inspection and Legal Fees:

(1) THE sum specified in 1.15 of Schedule 1 has been paid to the Council in respect of the costs incurred by the Council in inspecting the Works

(2) THE sum specified in 1.16 of Schedule 1 has been paid to the Council in respect of the Council's legal fees

(3) (3) RECEIPT by the Council of the payment of such sum shall not create any contractual relationship between the Council and the Owner nor absolve the Owner from any liability or obligation imposed upon him by the terms of this agreement or by statute or at common law and the Council will not be liable for any loss damage or injury which the Owner may sustain by reason of insufficient or faulty inspection of the Works by the Council

17. Determination by the Council:

IF the Owner fails to perform or observe any of the conditions stipulations or obligations on his part contained herein or if the Owner is adjudged bankrupt or if the Owner is being wound up or if the Owner enters into a composition or scheme of arrangements (otherwise than for the purpose of amalgamation or reconstruction) the Council may without prejudice to any of its rights claims or remedies against the Owner in respect of such non-performance or non-observance determine this Agreement (except for clauses 17, 18 and 19 hereof) by notice in writing signed by the Engineer and delivered to the Owner or sent by post to the address stated in this Agreement

18. Power to Execute Works in Default:

WITHOUT prejudice to clauses 2 and 16 hereof if the Owner fails to execute or complete the Works in accordance with the Owner's obligations hereunder the Council shall after not less than twenty-eight days notice in writing to the Owner be entitled to execute or complete the Works in default by its own employees or by contract or otherwise and to recover the cost as

certified by the Engineer from the Owner

19. Surety's Obligations:

- (a) If the Owner at any time fails to perform or observe any of the conditions stipulations or obligations on his part contained in this agreement or if the Owner is adjudged bankrupt or if the Owner is being wound up or if the Owner enters into a composition or scheme of arrangement (otherwise than for the purpose of reconstruction or amalgamation) the Engineer may without prejudice to any statutory rights or powers or any other right claim or remedy under this agreement send to the Surety notice in writing (hereinafter referred to as the "Default Notice"):-
- (i) specifying the work (hereinafter referred to as the "Default Work") to be carried out in order that the Works may be executed out or completed as the case may be in accordance with this Agreement; and
 - (ii) containing an estimate by the Engineer of the cost of carrying out the Default Work and of the cost of maintaining the Works for a period of twelve months prior to the Road or Roads becoming maintainable at the public expense and also a statement of the amount of the usual establishment charges of the Council (together hereinafter referred to as the "Default Cost") which cost:-
 - (1) shall not exceed the sum specified in 1.3 of Schedule 1 being the Estimated Cost
 - (2) shall not exceed the sum specified in 1.17 of Schedule 1 on and after the issue of the Part 1 Certificate
 - (3) shall not exceed the sum specified in 1.18 of Schedule 1 on and after the issue of the Part 2 Certificate
- (b) Within twenty-eight days after the Surety has received the Default Notice the Surety shall:-
- (i) pay the Default Cost to the Council; or
 - (ii) send to the Council notice in writing (hereinafter referred to as the "Surety's Counter Notice") of the intention of the Surety to carry out the Default Work
- (c) If the Surety having sent the Surety's Counter Notice to the Council fails to start the Default Work within fifty-six days after the Surety received the Default Notice the Surety shall forthwith pay the Default Cost to the Council with simple interest thereon at the prevailing rate of Lloyds TSB Bank PLC plus 3 per cent per annum calculated from the date on which the Surety received the Default Notice
- (d) If the Surety having sent the Surety's Counter Notice to the Council starts the Default Work and the said work is not completed within four months after the Surety's Counter Notice was received by the Council or within such further period as may be agreed by the Council the Surety shall subject to sub-clause (e) forthwith on demand by the Engineer pay to the Council such sum as the Engineer may determine as being the cost of carrying out any Default Work not carried out by the Surety or the cost of maintaining the Works for the period of twelve months prior to the Road or Roads becoming maintainable at the public expense as may be the case (or as being the cost of both) and also pay to the Council the amount determined by the Engineer as being the amount of the appropriate usual establishment charges of the Council
- (e) The sum payable under sub-clause (d) shall not exceed the Default Cost and the covenant in clause 19(c) shall apply with respect to such sum and on the issue of the Final Certificate the Surety shall be released from all liability hereunder

20. Council's Covenants:

THE Council HEREBY COVENANTS with the Owner and with the Surety for the benefit of all building plots fronting adjoining or abutting the Road or Roads and for each and every one of them:

- (a) to use its best endeavours in consultation with the Surety to mitigate any loss or damage sustained by reason of any default by the Owner by taking such reasonable steps as the Council shall think fit
- (b) to apply all monies received from the Surety as hereinbefore mentioned towards the expenditure involved in executing or completing the Works and maintaining and making good all defects for a period of twelve months after completion and the amount so received shall be deducted from any sum which would otherwise be recoverable from the owner(s) of premises fronting the Road or Roads under the provisions of the Highways Act 1980 or any other act for the time being in force replacing or amending the same
- (c) in the event of the sum paid by the Surety to the Council exceeding the cost of executing or completing the Works and maintaining and making good all defects as aforesaid together with the amount of the Council's usual establishment charges to repay to the Surety within twenty-eight days after the Road or Roads become maintainable at the public expense the amount of such excess with interest calculated at half-yearly rests on the unexpended balance for the time being of the sum paid by the Surety to the Council at the rate of interest prevailing from time to time on monies held in a deposit account with the Council's bankers

THE Council HEREBY FURTHER COVENANTS that the Final Certificate will be issued in accordance with this Agreement and that the Surety will be released from all liability under this Agreement in accordance with this agreement

21. Part or Parts:

NOTWITHSTANDING anything hereinbefore contained the Owner may from time to time during the currency of this agreement apply to the Engineer for his Part 1 Certificate or his Part 2 Certificate in respect of any part of the Road or Roads (being the whole width of the Road or Roads between points to be defined in the application) and if the Engineer shall be satisfied that the part so defined is in all respects suitable to be treated as a separate Road or Roads for the purposes of construction and adoption in accordance with the several provisions contained in this agreement then he shall issue a separate Part 1 Certificate or Part 2 Certificate as the case may be in respect of that part and thereafter the same proceedings may be taken in respect of the said part of the Road or Roads as if the said part were the subject of a separate agreement under which the terms of this agreement applied to the said part separately from the remainder of the Road or Roads but without prejudice to the application of this Agreement to the remainder of the Road or Roads and the liability of the Surety shall be reduced as may be agreed by the Engineer with the Owner

22. Assignment:

THIS Agreement may not be assigned by the Owner without the written consent of both the Council and the Surety which consent shall not be unreasonably withheld

23. Arbitration:

IN the event of any dispute arising out of this Agreement the same shall be referred to a sole arbitrator to be agreed between the parties or failing agreement to be appointed by the President for the time being of the Institution of Civil Engineers and in this respect this Agreement shall be construed as a submission to arbitration within the meaning of the

Arbitration Acts 1996 or any statutory re-enactment or modification thereof

24. Advance Payments Code:

UPON the execution of this Agreement payments made or securities given to the Council under section 219 of the Highways Act 1980 in respect of those plots detailed in Part 3 of Schedule 2 to this Agreement which front the Road or Roads are hereby released / refunded with interest accrued from the date of deposit to the date of the Agreement as the case may be to the extent indicated

OR

AS from the date of execution of this Agreement any notices served by the Council requiring payments or security under the advance payments code in relation to buildings having a frontage to the Road or Roads will not be enforced by the Council

25. Road or Roads Joining a Public Highway or Highways:

NOTWITHSTANDING anything hereinbefore contained the Engineer shall be under no obligation to issue a Certificate under clause 9 hereof until the Road or Roads the subject of this Agreement shall join a public highway or highways

26. Third Party Rights

IT is hereby agreed and declared that a person who is not a party to this Agreement shall not be entitled in his or her own right to enforce any term of this Agreement pursuant to the Contracts (Rights of Third Parties) Act 1999

27. Speed Survey

IF so requested in writing by the Engineer the Owner shall at his own cost and prior to the issue of the Part 2 Certificate carry out a Speed Survey to determine what if any further measures are necessary for the effective implementation of the 20mph Zone on the Road or Roads

28. Parking Restrictions

- (1) THE Owner at his own expense shall carry out works to give effect to the parking restrictions if so required in writing by the Council prior to the issue of the Part 2 Certificate
- (2) THE Owner shall pay to the Council the Parking Restrictions sum specified in 1.10 of Schedule 1 arising out of the provision of traffic regulation or other orders and the implementation of such statutory or other procedures in relation to the parking restrictions if so required in writing by the Council prior to the issue of the Part 2 Certificate

29. Chargees

THE Chargees have agreed to provide letters of consent which are annexed to this Agreement under ANNEX 1 and do not require to be party to this Agreement to signify their respective consents to this Agreement progressing

SCHEDULE 1

1.1	Drawings	Numbered
1.2	Section Drawings	Numbered

1.3	Estimated Cost	£
1.4	Maintenance Period	
1.5	[Traffic Management Measures Sum] [20mph Zone Orders Sum]	£
1.6	Commuted Sum	£
1.7	Commuted Sum features	£
1.8	Commuted Sum Drawing	Numbered
1.9	Parking Restrictions Plan	Numbered
1.10	Parking Restrictions Sum	£
1.11	Greenfield Cost	£
1.12	Date for completion of Works	
1.13	Number of calendar months for completion of Part 1 Works	
1.14	Number of calendar months for completion of Part 2 Works	
1.15	Inspection fee	£
1.16	Legal fees	£
1.17	Part 1 Certificate default cost	£
1.18	Part 2 Certificate default cost	£

SCHEDULE 2

Part 1

1. All highway drainage
2. All other drainage contained within the highway
3. All kerb foundations and where appropriate kerbs including lowering at vehicle crossings and pram-ramps
4. Carriageway sub-base road base and any supporting structures thereto
5. Carriageway base course surfacing where appropriate
6. Demarcation of sight lines and clearance of vision splays

Part 2

7. All outstanding kerbing not completed in Part 1
8. Pedestrian ways
9. Carriageway wearing course and/or carriageway base course
10. Vision splays and verges
11. Street lighting and street furniture
12. Street name plates
13. Road markings
14. All other Works described in the Specification and shown in the Drawings

Part 3

Plot Nos.	Sum (£)	Date of APC Notice and Reference	DEVELOPER/OWNER	Form and Date of Security Given
[S1a]	[S2a]			
[S1b]	[S2b]			
[S1c]	[S2c]	[S3]	[S5]	[S6]
[S1d]	[S2d]	[S4]		[S7]
[S1e]	[S2e]			
[S1f]	[S2f]			
etc	etc			

TOTAL	[S8]			
--------------	-------------	--	--	--

This document has been executed as a deed and delivered the day and year first before written

THE COMMON SEAL of)
THE OWNER was hereunto)
affixed in the presence of:)

Director

[Print Name]

Secretary/Director

[Print Name]

THE COMMON SEAL of THE)
COUNCIL was hereunto affixed)
in the presence of:)

THE COMMON SEAL of THE)
SURETY was hereunto affixed)
in the presence of:)

Authorised Signatory

[Print Name]

Executed as a deed (but not delivered until the date inserted above) by affixing the common seal of ***** in the presence of:

Authorised Signatory

EXECUTED as a DEED on behalf of)
***** by)
and)
in exercise of the powers conferred)
on them by a Power of Attorney dated)
the day of who have)
hereunto set their names in the presence of:)

Signed as his deed by the said)
)
in the presence of:-)

1st Witness Signature:
Name:
Address:
.....

2nd Witness Signature:
Name:
Address:
.....

Executed as a deed on behalf of)
*****)
***** by its)
authorised signatories:-)

Director

[Print Name]

Secretary/Director

[Print Name]

DATED

DEVELOPER/OWNER

-and-

ESSEX COUNTY COUNCIL

-and-

SURETY

AGREEMENT

Under Section 38 of the Highways Act 1980 Section 111 of the Local Government Act 1972 and Section 33 of the Local Government (Miscellaneous Provisions) Act 1982 in connection with the development ***** in the Parish of ***** in the District/Borough of ***** in the County of Essex

(Estate No: [H1])

(Phase [H2])

Paul Turner
Director for Legal and Assurance

Essex County Council
Seax House
Victoria Road South
Chelmsford
Essex CM1 1QH

ANNEXURE E
PROCESS MAP

PART A – PRE-AGREEMENT STEPS

INITIAL APPROACH WITH LAYOUT DRAWING – DRAFT AGREEMENT PREPARED

ENGROSSMENTS EXECUTED BY DEVELOPER/LAND OWNERS

ECC LEGAL FEES PAID

AGREEMENT COMPLETED

PART B – POST AGREEMENTS STEPS

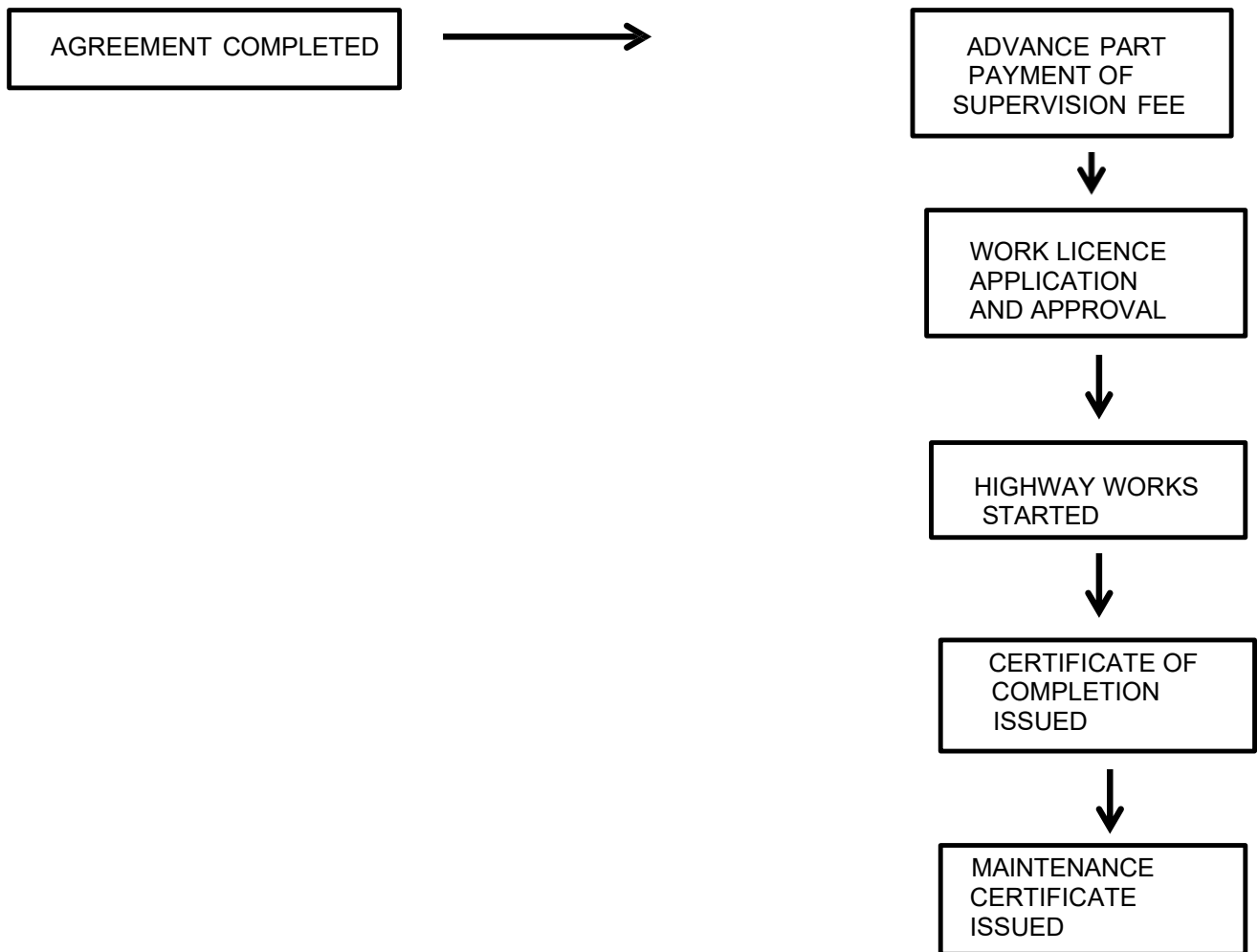

APPENDIX J - DEPARTURES FROM STANDARD POLICY – DEVELOPMENT MANAGEMENT

Appendix J

The Departure From Standard process is currently under review.

An updated Appendix will be provided in due course.

*For any departure from standard queries please contact
Development.management@essexhighways.org for further
guidance*

APPENDIX K - DEVELOPMENT MANAGEMENT ROAD OPENING NOTICE

Development Management sits outside the Essex Permit Scheme and therefore road space needs to be booked using the Development Management Road Opening Notice Form **accompanied by the Traffic Management Assessment Form and an A3 1:500 scale plan, certifying 'All traffic management to comply with Chapter 8 and any updates and Safety at Street Works (A Code of Practice)'**. If you have any works being carried out on a new development under a Section 38, Section 278 or a minor works authorisation using the Highways Act 1980 then you will need to process your scheme with the Project Engineer/Technician allocated to you from the Development Management Team but at some point the person undertaking the works will need to apply for your Road Opening Notice under the New Roads and Street Works Act 1991.

It is a good idea to approach your Streetworks Co-ordinator (see below) early on in the implementation of your project to plan your works accordingly and have a realistic timescale.

Please contact the Development Management team using the following email address if you have not already done so or have any queries

development.management@essexhighways.org

How to Process a Road Opening Notice

The following information is mandatory for this process

1. What are the works you plan to carry out and how long are they expected to take? Please see the table below for timescales and notice periods required:

Minor Notice	Requires 3 working days' notice
Standard Notice	Requires 10 working days' notice
Major Works	Requires 3 months' notice, followed by a 10-day notice before the start date which will have the actual start date

2. Have you spoken to a Streetworks Site Consultant? Please see the table below to find your nearest contact:

Districts Covered	Site Consultant
Uttlesford, Harlow, Epping Forest, Brentwood, Basildon, Castlepoint and Rochford	Mr Ray White raymond.white@essexhighways.org
Braintree, Colchester, Tendring, Chelmsford and Maldon	Mr Ben Runham ben.runham@essexhighways.org

3. Have all the appropriate information/documents/drawings been submitted to a Development Management Project Engineer? (**Traffic Management Assessment Form, Traffic Management Plan - A3 1:500 scale, certifying 'All traffic management to comply with Chapter 8 and any updates and Safety at Street Works (A Code of Practice)', Confirmation of a £10 million Public Liability Insurance, NRSWA Supervisor and Operatives Streetworks cards.**)

<https://www.essexhighways.org/dm-road-opening-notice>

Submitting and closing down NRSWA Road Opening Notices

Before a developer or contract apply for a Road Opening Notice, the Project Engineer should be fully aware of the scheme and be confident that a notice can be submitted. To prevent notices being rejected by the Streetworks Team, all forms must be submitted to DM.BusMan@essexhighways.org

The Streetworks co-ordinators are available to applicants to discuss restrictions on the network but are not there to agree traffic management plans. The Co-ordinators names, contact information and the areas they cover are all contained within the Development Construction Manual.

	Timescale	Notice Period
Minor Notice	3 working days	Requires 3 works days' notice

Standard Notice	Up to 10 days	Requires 10 works days' notice
Major Works	3 months	Requires 3 months' notice and then followed up by a 10 day notice before the start date which will have the actual start date

Process:

1. Each scheme is different and has different lead in times/duration of works. The Project Engineer will advise the submission of a NRSWA form at the correct stage. Information relating to and the Road Opening Notice form including the Traffic Management Risk Assessment Form can be obtained on the Essex Highways website <https://www.essexhighways.org/applications/dm-road-opening-notice>
2. Once the Road Opening Notice form has been completed this should be submitted along with the Traffic Management Risk Assessment Form, Traffic Management Plan – A3 1:500 scale certifying 'All traffic management to comply with Chapter 8 and any updates and Safety at Street Works (A Code of Practice), Confirmation of a £10 Million Public Liability Insurance, NRSWA supervisor and Operatives Streetworks cards to DM.BusMan@essexhighways.org and this will be sent onto the correct Project Engineer.
3. The Project Engineer will review the form and accompanying information, paying particular attention to check that the date is realistic and that the grid reference has been completed.
4. Once all is correct, this is all sent through to the Streetworks team.
5. The Streetworks team will review the information and form and then advise if this has been accepted or not. If it is accepted then they will send through to the applicant, the reference number for their information board on site and any conditions. Any conditions will be added to the minor works authorisation or licence.
6. Developer to inform Project Engineer the actual start date of the works
7. Once the works are completed, the developer shall return the form back with the end date added. This is sent to the Streetworks team for the notice to be updated on the system and closed off. N.B. If this is not done then the job remains live on the Streetworks system.

Appendix L – RECENT UPDATES

Increase in fees and revision of commuted sums April 2017 **Page 183-190**

Addition of Section 38 Agreement July 2017 **Appendix I Page 209**

Renaming of TRSGD to 2016 from 2002 **Throughout document**

Compliance with DfT Guidance July 2017 **Page 178**

Addition of betterment and extra over guidance September 2017 **Page 186**

Addition of brickwork, lines, noise attenuation barrier and over size pipes to commuted sum rates September 2017 **Page 189-190**

Update of minimum fee to £1450 November 2017 **Page 183**

Addition of departures from standards process December 2017 **Appendix J Page 218**

Updates to 4.3.10, 4.3.24, 4.3.26 and 4.3.30 November 2018 **Pages 88, 92, 93 and 95**

Updates to commuted sum rates to add Coloured Asphalt and RTI Display November 2018 **Pages 188 and 189**

Updates to Fees for Traffic Regulation Orders, S228, S72 and S177 November 2018 **Pages 184,185,190 and 191**

Road opening notice procedure November 2018 **Page 225**

Street Lighting specification November 2018 **Pages 137-138**

Works Permit changed to Minor Works Authorisation **November 2018**

Update to gradients and gullies November 2018 pages **56, 62/63,166, 170,171,177, 178**

Updates to Fees for Traffic Regulation Orders, S228, S72 and S177 **Sept 2019. Pages 181 and 187.**

Updates to Fees **April 2020. Pages 180-182 and 187.**

Additional wording re: VRS **April 2020. Pages 123-124.**

Change of wording relating to the PSRV on manhole covers, as updated in the CD534 **April 2020. Page 88.**

Updates to Table 4 – Road Types as per the Essex Design Guide **April 2020. Pages 147-148.**

Updates to Fees **June 2022. Pages 180-182 and 187.**

Change of Ian 73/0 (superceded) to CD225 Design for New Pavement Foundations. Updated Table. **July 2022. Pages 70 and 139-140**

Updates to Fees **April 2023 Pages 168-169 and 174-176**

Suspension of Appendix J **July 2023 Page 200**

Inclusion of link to 2024 Street Lighting Specification **April 2024 Pages 33 and 54**

Inclusion of link to ITS Guidance **April 2024 Pages 28 and 34**

Inclusion of link to Structures Guidance **April 2024 Pages 28, 33 and 47**

NRSWA Contacts update **April 2024 Pages 38 and 202**

Criteria for power supply to Bus Shelters **April 2024 Page 178**

Amended wording for Staging of Inspection fee payment trigger **April 2024 Pages 167-168**

Clarification on As Built drawing requirements **April 2024 Page 43**

Updates to Fees **April 2024 Pages 167-169 and 174-176**

Addition of S38 and S278 Agreement to Appendix I **April 2024 Pages 191 onwards**

Inclusion of link to 2025 Street Lighting Specification **January 2025 Pages 33 and 54**

Updated rates for Commuted Sums **June 2025 Pages 172-174**

Inclusion of Carbon Reduction **June 2025 Pages 74 and 75**

4.5 Kerbing and Channelling update of specification to HB2 kerb face 100/125mm
June 2025 Page 98

4.6.5 Geosynthetics Geotextiles, geogrids, geomembranes etc. to BS EN
13249:2016 'Geotextiles and geotextile' **June 2025 Page 101**

Appendix A Table 5 Removal of reference to AC10 under Road Types A-D **June
2025 Page 137**

1.8 Types of Legal Agreements Inclusion of S171 Road Opening Notice information
for Trial Hole Investigation Works **June 2025 Page 25**

Requirement for colour to be used on Highway Drainage easements to be yellow on
pink plan **June 2025 Page 44**

2.5 Surface Water Drainage updated to current standards **June 2025 Pages 50-51**

Updates to Fees **April 2026 Pages 169-176**